



# DATASHEET

EYES

V1.3

# 1 Datasheet

## Eyes

Camera Characteristics	
Interface	USB-C 3.x
Image Sensor Technology	Rolling Shutter. 1.4µm x 1.4µm pixel size
RGB Camera Field of View (FOV)	69.4° x 42.5° x 77° (+/- 3°)
RGB Camera Resolution	1280x1080
Depth Technology	Active IR Stereo
Depth FOV	65°±2° x 40°±1° x 72°±2°
Depth Output Resolution	1280 x 720
Working Distance	400-1000 mm
Operating Temperature	0 – 35 °C
IP Rating	IP 54

Eyes Features		
Type of vision system	2.5 D	
Minimum part size	10x10 mm or 15 mm diameter	
Applications Supported	Detection, Sorting	
Mounting options supported	Robot and External	
Reconfigurability when Robot mounted	12 configurations (4 x 3)	
	Around robot's flange	Tilt orientations
	0 - 90 - 180 - 270 (degrees)	0 - 45 - 90 (degrees)
Processing time	Typical: 0.5 s	
Detection Repeatability	< 2 mm	
Detection Accuracy	External Mount	Robot Mount
	Typical: 2 mm	Typical: 2 mm

Application and set-up recommendations	
Lighting conditions	No drastic, instant changes
Reflections and focused light spots	Keep minimal
Characteristics of objects	Different from background
Camera with respect to workspace table	Looking straight to it

Eye Box	
Weight	1.01 kg
	2.23 lb
Required power supply	24V (5A)

**Robot Mount**

- 4 x  $\phi$  6.40 [0.252] THRU
- ✓  $\phi$  7 [0.276] X 90°, Near Side
- ✓  $\phi$  7 [0.276] X 90°, Far Side

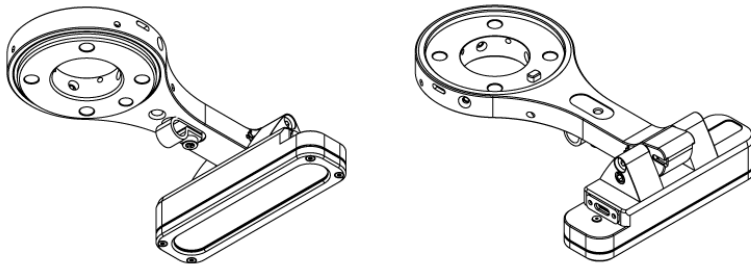
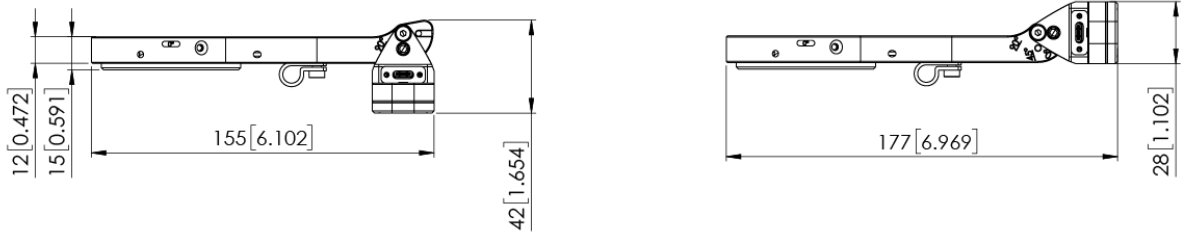
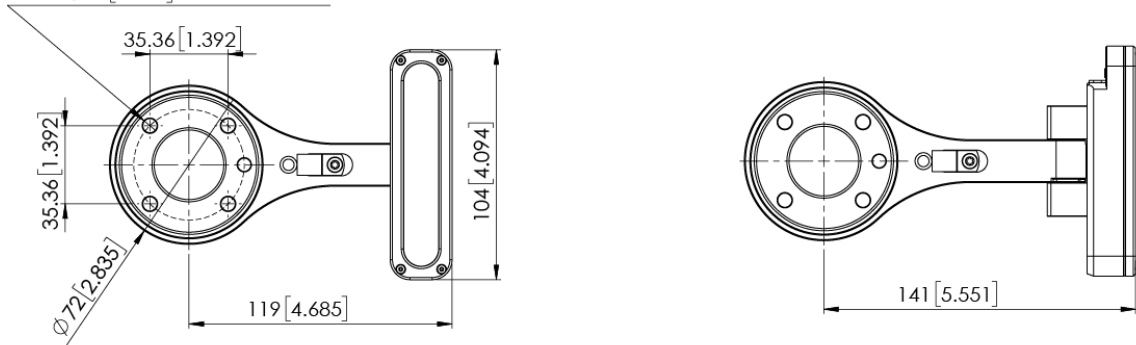

All dimensions are in mm and [inches].

**External Mount**

- 2 x  $\phi$  5.11 [0.201]  $\nabla$  8.5 [0.335]
- 1/4-20 UNC  $\nabla$  7 [0.276]
- ✓  $\phi$  6.38 [0.251] X 90°, Near Side

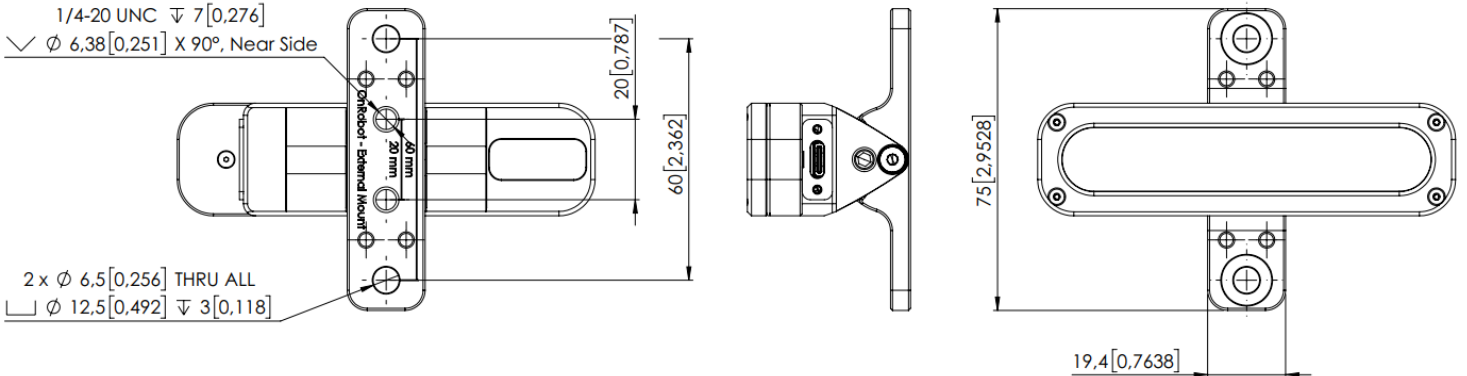

**Eye Box**

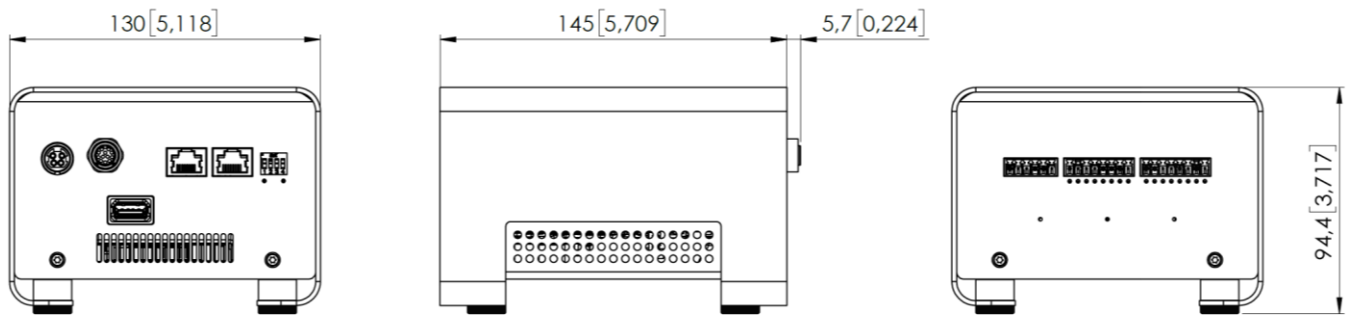

All dimensions are in mm and [inches].