



USER MANUAL

FOR HANWHA ROBOTS

ORIGINAL INSTRUCTION (EN)

v1.05

Contents

Contents	2
1 Introduction	4
1.1 Important Safety Notice	4
1.2 Scope of the Manual	4
1.3 Naming convention.....	4
1.4 How to read the Manual.....	5
2 Safety	6
2.1 Intended Use	6
2.2 General Safety Instructions.....	7
2.3 Risk Assessment.....	8
2.4 Environmental Safety	8
2.5 PLd CAT3 Safety Function	9
3 Operation mode(s)	10
4 Installation	11
4.1 Overview.....	11
4.2 Mounting	11
4.2.1 Quick Changer options.....	12
4.2.2 Tools.....	14
4.3 Wiring	20
4.3.1 Tool data.....	20
4.3.2 Digital I/O wires.....	20
4.3.3 Ethernet cable.....	23
4.3.4 Power supply.....	23
5 Operation	25
5.1 Overview.....	25
5.2 Ethernet Interface setup.....	26
5.3 Web Client.....	28
5.4 OnRobot WebLogic menu.....	30
5.4.1 Browser	30
5.4.2 Program Editor.....	31
6 Additional Software Options	37
6.1 Compute Box	37
6.1.1 Interfaces.....	37
6.1.2 Web Client.....	37
7 Hardware Specification	56
7.1 Technical sheets.....	56
7.2 Mechanical Drawings	94
7.2.1 Adapter plate(s)	94

7.2.2 Mountings.....	94
7.2.3 Tools.....	98
7.3 Center of Gravity.....	108
8 Maintenance.....	110
9 Warranties.....	113
9.1 Patents.....	113
9.2 Product Warranty	113
9.3 Disclaimer.....	113
10 Certifications.....	114
1.1 Declaration of Incorporation.....	120

1 Introduction

1.1 Important Safety Notice



DANGER:

You must read, understand, and follow all safety information in this manual, and the robot manual and all associated equipment before initiating robot motion. Failure to comply with safety information could result in death or serious injury.

1.2 Scope of the Manual

The manual covers the following OnRobot products and its components:

Grippers	Version
Gecko Gripper	v2
RG2	v2
RG2-FT	v2
RG6	v2
VG10	v2
VGC10	v1

Sensors	Version
HEX-E QC	v3
HEX-H QC	v3

Where applicable the combination of the products is also covered in the manual.



NOTE:

Generally, the products without the Quick Changer v2 interface, are not in the scope of this manual.

1.3 Naming convention

In the user manual Gecko Gripper is called Gecko only.

The RG2 and RG6 names as model variants are used separately or together as RG2/6 if the information is relevant for both variants.

The HEX-E QC and HEX-H QC names as model variants are used separately or together as HEX-E/H QC if the information is relevant for both variants.

1.4 How to read the Manual

The manual covers all OnRobot products and its components that is available for your robot.

To make it easy to follow what type of product (or combination) or component is the given information is relevant for, the following visual highlights are used:

RG2

This is an instruction relevant for the RG2 product only.

RG2-FT

This is an instruction relevant for the RG2-FT product only.

VG10

This is an instruction relevant for the VG10 product.

All text without these visual marks are relevant for all products or components.

For convenience, in each part that contains visual highlights (that span across pages) a table is provided in the beginning, to guide you which page contains the relevant information for your product or component:

 RG2	5
 RG2-FT	5
 VG10	5

2 Safety

The robot integrators are responsible for ensuring that the applicable safety laws and regulations in the country concerned are observed and that any significant hazards in the complete robot application are eliminated. This includes, but is not limited to:

- Performing a risk assessment for the complete robot system
- Interfacing other machines and additional safety devices if defined by the risk assessment
- Setting up the appropriate safety settings in the robot software
- Ensuring that the user will not modify any safety measures
- Validating that the total robot system is designed and installed correctly
- Specifying instructions for use
- Marking the robot installation with relevant signs and contact information of the integrator
- Collecting all documentation in a technical file; including the risk assessment and this manual

2.1 Intended Use

OnRobot tools are intended to be used on collaborative robots and light industrial robots with different payloads depending on the end-of-arm tooling specifications. OnRobot tools are normally used in pick-and-place, palletizing, machine tending, assembly, quality testing and inspection and surface finishing applications.

The end-of-arm tooling should only operate under conditions noted in **Technical sheets** section.

Any use or application deviating from intended use is deemed to be impermissible misuse. This includes, but is not limited to:

- Use in potentially explosive atmospheres
- Use in medical and life critical applications
- Use before performing a risk assessment
- Use outside the permissible operational conditions and specifications
- Use close to a human's head, face and eye area
- Use as a climbing aid

2.2 General Safety Instructions

Generally, all national regulations, legislations and laws in the country of installation must be observed. Integration and use of the product must be done in compliance with precautions in this manual. Particular attention must be paid to the following warnings:



DANGER:

You must read, understand, and follow all safety information in this manual, and the robot manual and all associated equipment before initiating robot motion. Failure to comply with safety information could result in death or serious injury.

The information in this manual does not cover designing, installing, and operating a complete robot application, nor does it cover other peripheral equipment that can influence the safety of the complete system. The complete system must be designed and installed in accordance with the safety requirements set forth in the standards and regulations of the country where the robot is installed.

Any safety information provided in this manual must not be construed as a warranty, by OnRobot A/S, that the robot application will not cause injury or damage, even if robot application complies with all safety instructions.

OnRobot A/S disclaims any and all liability if any of OnRobot tools tooling are damaged, changed or modified in any way. OnRobot A/S cannot be held responsible for any damages caused to any of OnRobot tools tooling, the robot, or any other equipment due to programming errors or malfunctioning of any of OnRobot tools.



WARNING:

OnRobot tools are not allowed to be exposed to condensing conditions when power is on or when connected to a robot. If condensing conditions appear during transport or storage, the product must be placed between 20 and 40 Celsius degrees for 24 hours before power is applied or before connected to a robot.

It is recommended that OnRobot tools are integrated in compliance with the following guides and standards:

- ISO 10218-2
- ISO 12100
- ISO/TR 20218-1
- ISO/TS 15066

2.3 Risk Assessment

The robot integrator must perform a risk assessment on the complete robot application. OnRobot tools are only components in a robot application and therefore they can be only safely operated if the integrator has considered the safety aspects of the whole application. OnRobot tools are designed with relatively smooth and round design with a limited amount of sharp edges and pinch points

In collaborative applications, the trajectory of the robot can play a significant safety role. The integrator must consider the angle of contact with a human body, e.g. orientate OnRobot tools and workpieces so that the contact surface in the direction of movement is as large as possible. It is recommended that the tool connectors are pointed in the direction opposite to the movement.

OnRobot A/S have identified the potential hazards listed below as significant hazards that must be considered by the integrator:

- Objects flying from OnRobot tools due to loss of grip
- Objects falling down from OnRobot tools due to loss of grip
- Injuries due to collisions between humans and workpieces, OnRobot tools tooling, robot or other obstacles
- Consequences due to loosen of bolts
- Consequences if OnRobot tools cable gets stuck to something
- Workpiece itself represents a hazard

2.4 Environmental Safety

OnRobot A/S products must be disposed of in accordance with the applicable national laws, regulations and standards.

The product is produced with restricted use of hazardous substances to protect the environment; as defined by the EU RoHS Directive 2011/65/EU. These substances include mercury, cadmium, lead, chromium VI, polybrominated biphenyls and polybrominated diphenyl ethers.

Observe national [registration](#) requirements for importers according to EU WEEE Directive 2012/19/EU.

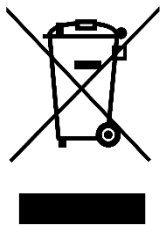

2.5 PLd CAT3 Safety Function

RG2
RG6

A safety-rated function has been designed as two buttons at the two arms of the product, conforming to ISO 13849-1 PLd CAT3.

This Safety Function has a max response time of 100 ms and a MTTF of 2883 years.

The behavior of the safety system is described below:

If something activates the two Safety Buttons, see picture below, the safety control system stops motion of the two arms of the product. Motion is then prevented as long as one or both of the two buttons are activated.

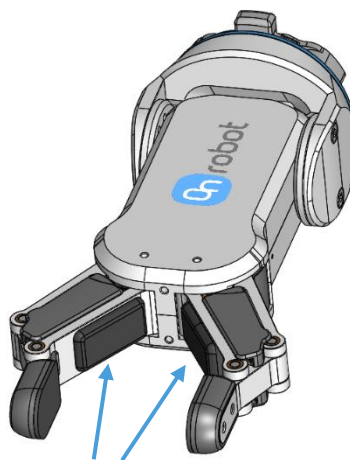

PLd CAT3 Safety Buttons

If this happens while running the robot program, user can detect this condition with the help of the provided status information and execute any necessary step on the robot.

To come back to normal operation with the gripper there are provided commands to reset the gripper.



CAUTION:

Before resetting the gripper always make sure that no part will be dropped due to the loss of gripper power. If Dual Quick Changer is used it will cycle the power for both sides.

For further details refer to the Operation section.

3 Operation mode(s)

There is one way how the device(s) could be used:

Mode(s) of Operation	
OnRobot WebLogic <i>required in the robot: digital I/O module</i>	

OnRobot WebLogic

This mode allows simple Digital I/O communication to be used to operate the grippers/sensor.

For example the Compute Box could be easily programmed to:

- when one of the robot digital outputs is set to HIGH, then the RG2 gripper opens to 77mm
- or when the force values measured with the HEX-E QC reach 50N, the Compute Box sends a HIGH digital output to the robot.

The Compute Box has 8 digital inputs and 8 digital outputs that can be freely configured for any "logic".

In this way the user can configure:

- eight gripper/sensor controlling functionality (e.g.: set width to X, close, zero, set preload, etc.)
- and eight gripper/sensor monitoring functionality (e.g.: is grip detected, is preload > 50N, etc.).

Furthermore, the "logic" can be complex, like:

- is grip detected AND force >20N

These "logics" can be programmed through the Compute Box's web interface called Web Client. It requires only a normal computer with a browser.

In this document this mode of operation will be covered and will be referred to as:

- OnRobot WebLogic

4 Installation

4.1 Overview

For a successful installation the following steps will be required:

- Mount the components
- Wire the cables
- Setup the software

In the following sections, these installation steps will be described.

4.2 Mounting

Required steps:

- Mount the Quick Changer option
- Mount the tool(s)

In the following two subsections these two mounting steps will be described.

4.2.1 Quick Changer options

Quick Changer - Robot Side

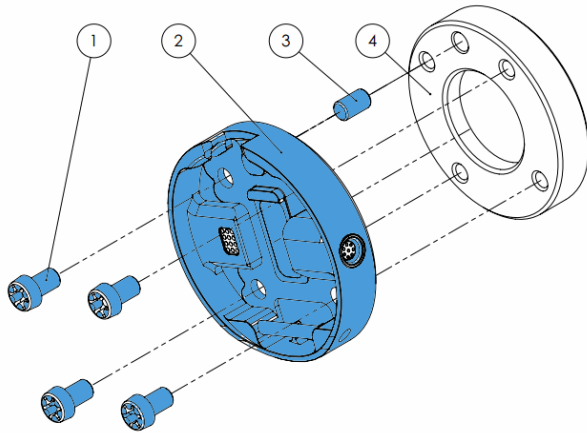

Quick Changer - Robot Side

- 1 M6x8mm (ISO14580 8.8)
- 2 Quick Changer (ISO 9409-1-50-4-M6)
- 3 Dowel pin \varnothing 6x10 (ISO2338 h8)
- 4 Adapter/ Robot tool flange (ISO 9409-1-50-4-M6)

Use 10 Nm tightening torque.

Dual Quick Changer

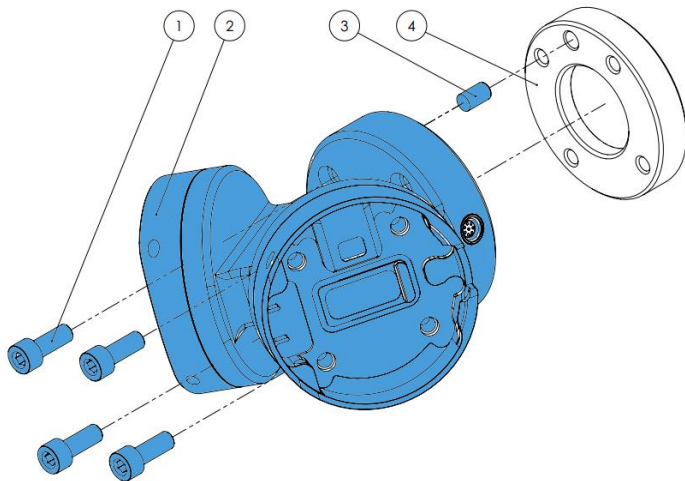

Dual Quick Changer

- 1 M6x20mm (ISO14580 8.8)
- 2 Dual Quick Changer
- 3 Dowel pin \varnothing 6x10 (ISO2338 h8)
- 4 Adapter/ Robot tool flange (ISO 9409-1-50-4-M6)

Use 10 Nm tightening torque.

HEX-E/H QC

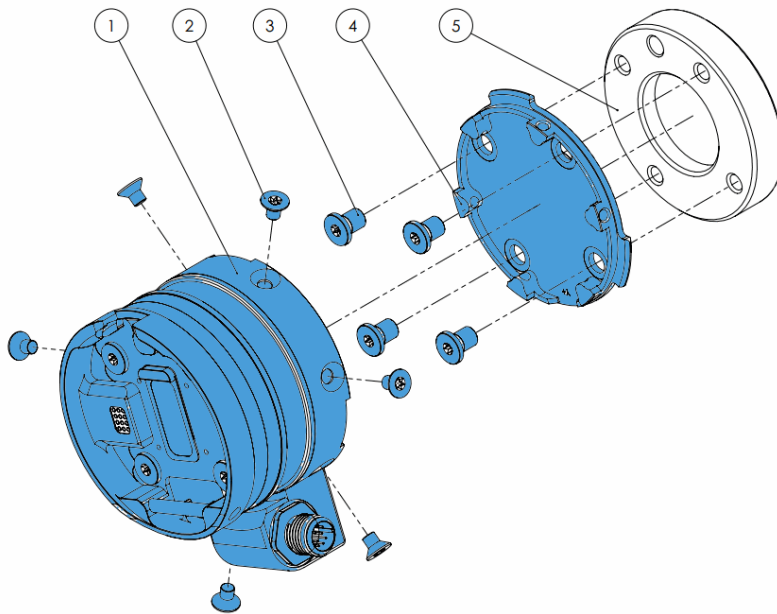

HEX-E/H QC

- 1 HEX-E/H QC sensor
- 2 M4x6mm (ISO14581 A4-70)
- 3 M6x8mm (NCN20146 A4-70)
- 4 HEX-E/H QC adapter
- 5 Adapter/ Robot tool flange (ISO 9409-1-50-4-M6)

Use 1.5 Nm tightening torque. for M4x6mm

Use 10 Nm tightening torque. for M6x8mm

4.2.2 Tools

	Gecko.....	14
	RG2.....	15
	RG2-FT	16
	RG6.....	17
	VG10.....	18
	VGC10.....	18
	Quick Changer - Tool side.....	19

Gecko

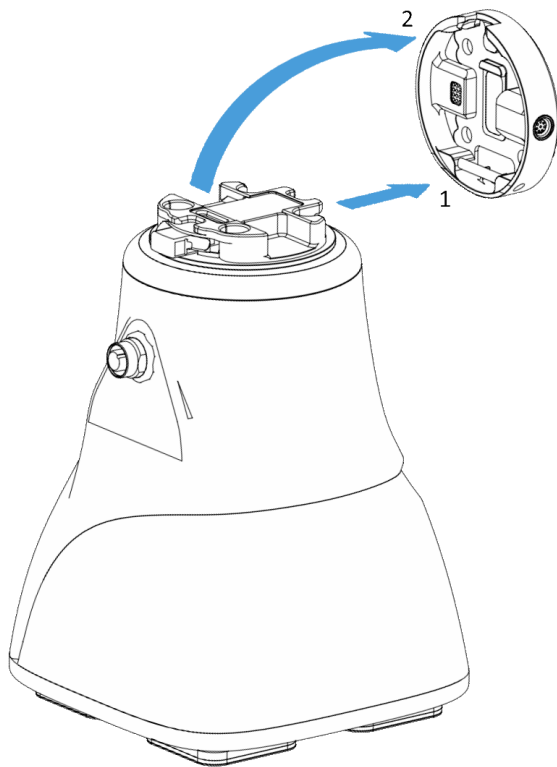

Step 1:

Move the tool close to the Quick Changer as illustrated.

The hook mechanism (rod and hook tongue) will keep the lower part locked once mounted.

Step 2:

Flip the tool until it is fully mated, and you hear a clicking sound.

To unmount the tool, press the aluminum button on the Quick Changer and repeat the steps in the reverse order.



CAUTION:

With a Dual Quick Changer the Gecko Gripper can only be mounted on the Secondary (2) side. Mounting on the Primary (1) side will prevent the devices to function correctly.

RG2

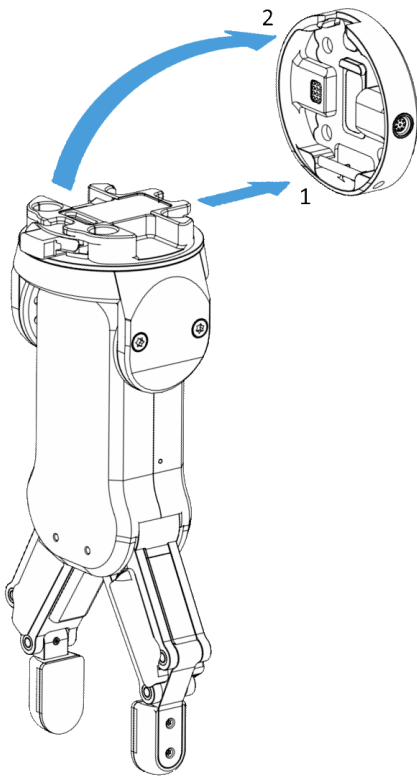

Step 1:

Move the tool close to the Quick Changer as illustrated.

The hook mechanism (rod and hook tongue) will keep the lower part locked once mounted.

Step 2:

Flip the tool until it is fully mated, and you hear a clicking sound.

To unmount the tool, press the aluminum button on the Quick Changer and repeat the steps in the reverse order.

To change the relative angle of the gripper to the Quick Changer:

- first remove the four M4x6 screws
- tilt the gripper between -90° and 90°
- then put the four M4x6 screws back and use 1.35 Nm tightening torque to fix it.

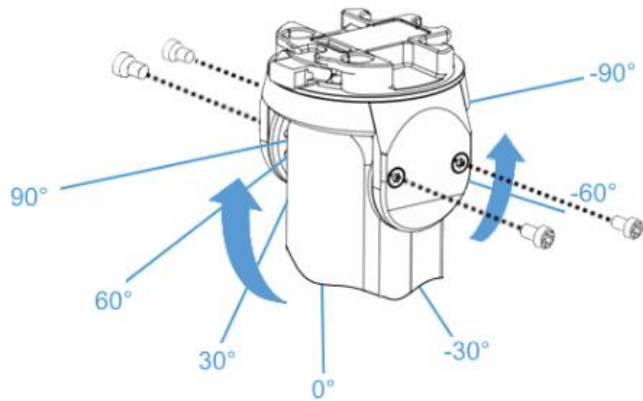

WARNING:

Never use the device while any of the four M4x6 screws are removed.

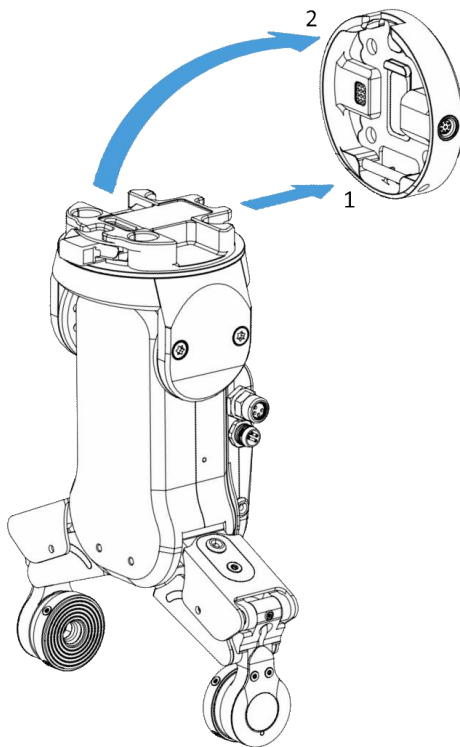
RG2-FT
**Step 1:**

Move the tool close to the Quick Changer as illustrated.

The hook mechanism (rod and hook tongue) will keep the lower part locked once mounted.

Step 2:

Flip the tool until it is fully mated, and you hear a clicking sound.

To unmount the tool, press the aluminum button on the Quick Changer and repeat the steps in the reverse order.

To change the relative angle of the gripper to the Quick Changer:

- first remove the four M4x6 screws
- tilt the gripper between -60° and 90°
- then put the four M4x6 screws back and use 1.35 Nm tightening torque to fix it.

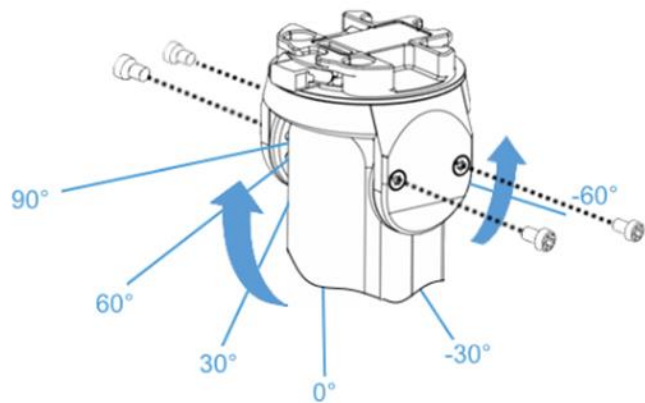
**WARNING:**

Never use the device while any of the four M4x6 screws are removed.

RG6

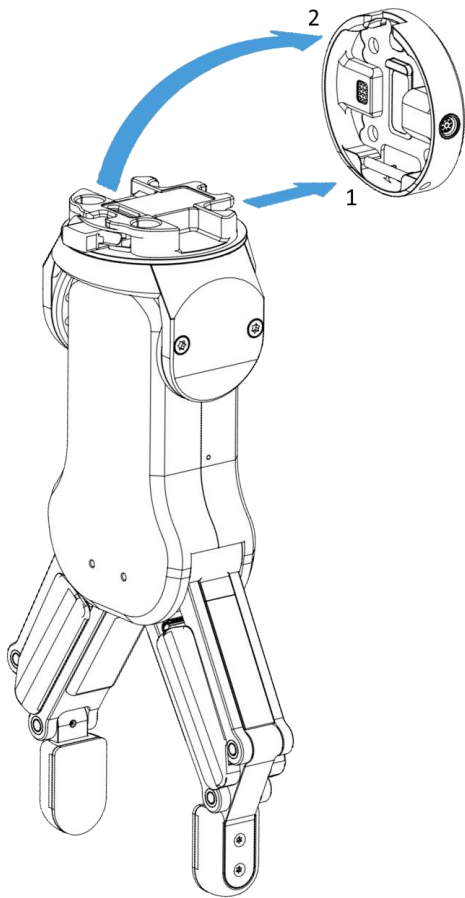

Step 1:

Move the tool close to the Quick Changer as illustrated.

The hook mechanism (rod and hook tongue) will keep the lower part locked once mounted.

Step 2:

Flip the tool until it is fully mated, and you hear a clicking sound.

To unmount the tool, press the aluminum button on the Quick Changer and repeat the steps in the reverse order.

To change the relative angle of the gripper to the Quick Changer:

- first remove the four M4x6 screws
- tilt the gripper between -90° and 90°
- then put the four M4x6 screws back and use 1.35 Nm tightening torque to fix it.

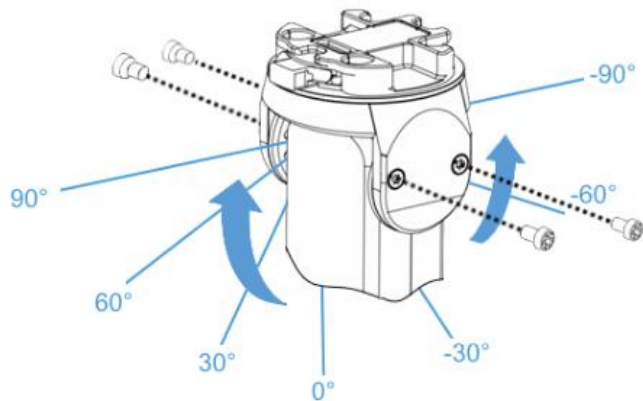

WARNING:

Never use the device while any of the four M4x6 screws are removed.

VG10

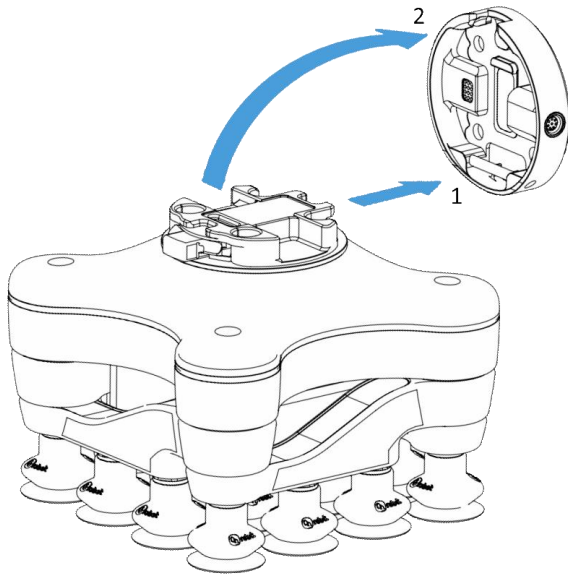

Step 1:

Move the tool close to the Quick Changer as illustrated.

The hook mechanism (rod and hook tongue) will keep the lower part locked once mounted.

Step 2:

Flip the tool until it is fully mated, and you hear a clicking sound.

To unmount the tool, press the aluminum button on the Quick Changer and repeat the steps in the reverse order.

VGC10

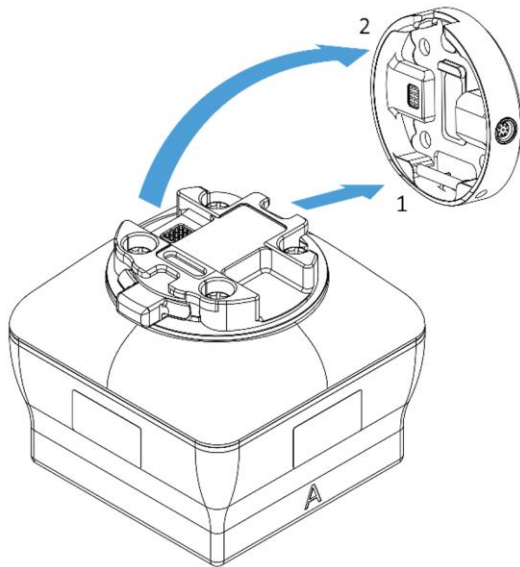

Step 1:

Move the tool close to the Quick Changer as illustrated.

The hook mechanism (rod and hook tongue) will keep the lower part locked once mounted.

Step 2:

Flip the tool until it is fully mated, and you hear a clicking sound.

To unmount the tool, press the aluminum button on the Quick Changer and repeat the steps in the reverse order.

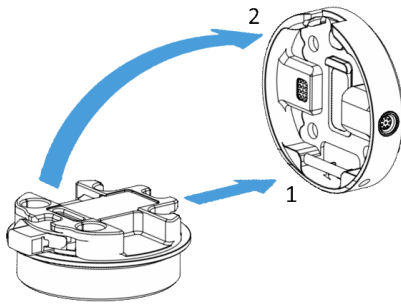
**Quick Changer -
Tool side****Step 1:**

Move the tool close to the Quick Changer as illustrated.

The hook mechanism (rod and hook tongue) will keep the lower part locked once mounted.

Step 2:

Flip the tool until it is fully mated, and you hear a clicking sound.

To unmount the tool, press the aluminum button on the Quick Changer and repeat the steps in the reverse order.

4.3 Wiring

Four kind of cables have to be connected to wire the system properly:

- Tool data cable between the tool(s) and the Compute Box
- The provided Digital I/O wires between the Computer Box and the robot controller
- Ethernet communication cable between the Compute Box and your computer
- Power supply of the Compute Box

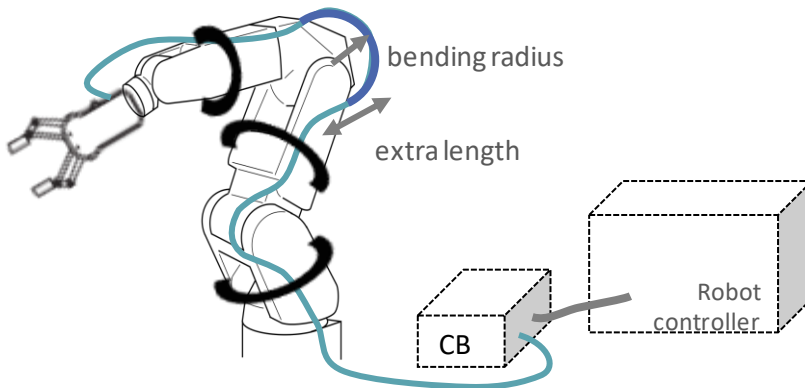

4.3.1 Tool data

Connect the data cable to the tool(s) then route the cable (blue line) to the Compute Box (CB) and use the supplied Velcro tape (black) to fix it.



NOTE:

Leave some extra cable length around the joints so that the cable is not pulled when the robot moves.

Also make sure that the cable bending radius is minimum 40mm (for the HEX-E/H QC it is 70mm)

Then, connect the other end to the Compute Box's DEVICES connector.



CAUTION:

Use only original OnRobot tool data cables.

4.3.2 Digital I/O wires

For Hanwha robots, the I/O interface inside the control cabinet can be used connect the Compute Box to the robot controller.

Make sure that the robot is powered off completely.

Configure the Compute Box DIP switches (red) to PNP:

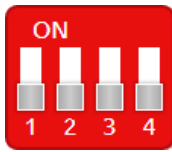

For **PNP** type set the 1. and 2. DIP switches to OFF position (down).

DIP switch 1: Digital Input mode
 DIP switch 2: Digital Output mode



NOTE:

Do not change the DIP switch 3 and 4 otherwise the network settings will be changed.

Plug in the supplied green pluggable connectors.

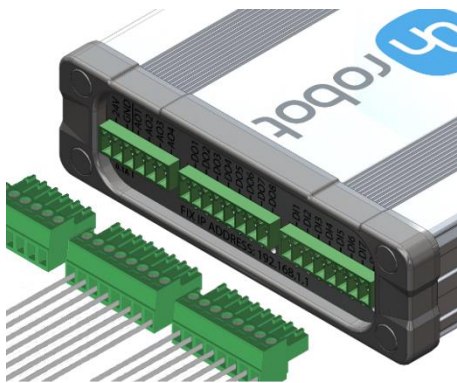

The supplied connector types are:

- 2 x Phoenix Contact MC 1,5/8-ST-3,5 Terminal Block
- 1 x Phoenix Contact MC 1,5/6-ST-3,5 Terminal Block

Wire the digital I/O wires from the Compute Box to the robot.

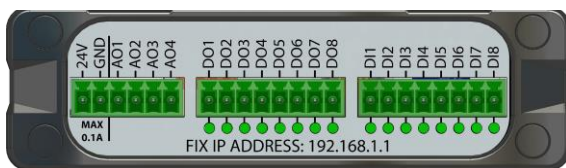

DO1-8: Digital outputs of the Compute Box (signals from the grippers/sensor to the robot)

DI1-8: Digital inputs of the Compute Box (signals from the robot to the grippers/sensor)

GND: To be used to have a common ground between the robot and the gripper/sensor

It is recommended to connect all 8 inputs and 8 outputs for simplicity.



CAUTION:

If some of the DO1-8 or DI1-8 wires will not be connected, make sure to unscrew it from the terminal block to avoid an accidental short circuit.



CAUTION:

The 24V and GND pins are only Reference Voltage Output. It cannot be used to power any equipment.

It is recommended to use the supplied wires only. If it is necessary to use different wire, use one that is shorter than 3 m.

Connect the Compute Box inputs to the robot outputs and the Compute Box outputs to robot inputs.

For simplicity, it is recommended to map the pins in order:

- | | |
|------------------------------------|-------------------------------------|
| DO1 to the robot's Digital input 1 | DI1 to the robot's Digital output 1 |
| DO2 to the robot's Digital input 2 | DI2 to the robot's Digital output 2 |
| ... | ... |
| DO8 to the robot's Digital input 8 | DI8 to the robot's Digital output 8 |

List of the important pins of the IO terminal blocks:

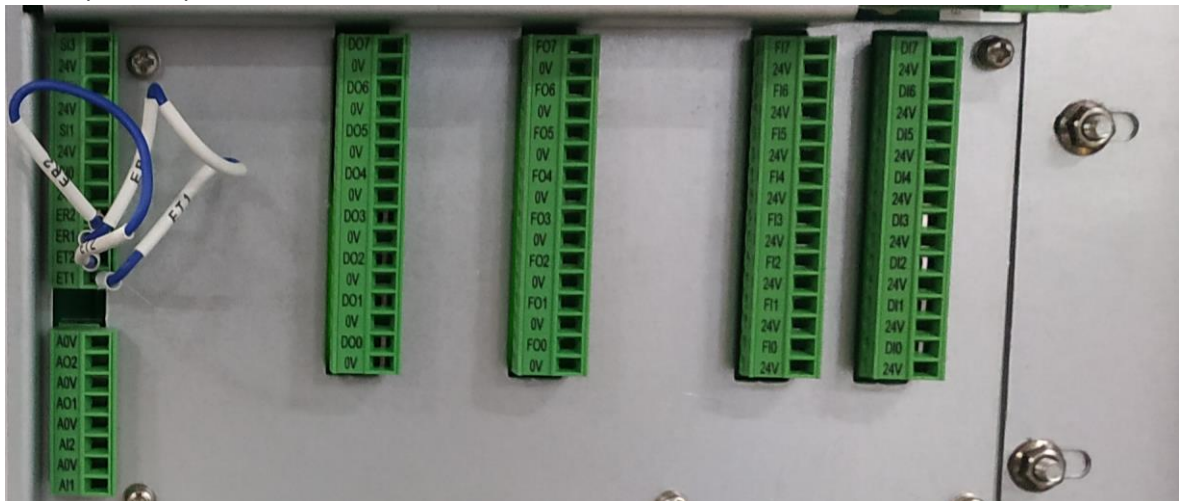

Pin	Description	Pin	Description
DI0	Digital input 1	DO0	Digital output 1
DI1	Digital input 2	DO1	Digital output 2
DI2	Digital input 3	DO2	Digital output 3
DI3	Digital input 4	DO3	Digital output 4
DI4	Digital input 5	DO4	Digital output 5
DI5	Digital input 6	DO5	Digital output 6
DI6	Digital input 7	DO6	Digital output 7
DI8	Digital input 8	DO8	Digital output 8
0V	Ground		

Please note which pin you used during the wiring, in a later step it is going to be needed for the mapping.

To have a common signal ground the following two pins needs to be wired together:

Pins from	Pins to	Description
Compute Box's GND	Robot's GND	Compute Box GND to 0V

4.3.3 Ethernet cable



Connect the provided Compute Box (ETHERNET connector) and your computer with the supplied UTP cable.

This connection is only needed for programming.



CAUTION:

Use only original OnRobot ethernet cables or replace it with one that is shielded and no more than 3 meter long.



WARNING:

Check and make sure that the Compute Box enclosure (metal) and the robot controller enclosure (metal) are not connected (no galvanic connection between the two).

4.3.4 Power supply



Connect the supplied power supply to the Compute Box 24V connector.



NOTE:

To disconnect the power connector, make sure to pull the connector housing (where the arrows are shown) and not the cable.



CAUTION:

Use only original OnRobot power supplies.

Finally, power up the power supply that will power the Compute Box and the connected Tool(s).

5 Operation

**NOTE:**

It is assumed that the Installation has finished successfully. If not, first do the installation steps in the previous section.

5.1 Overview

OnRobot WebLogic requires to be programmed first with the help of a computer connected to the Compute box. Then it can run standalone without any Ethernet connection.

Steps to program it:

- Setup the Compute Box's Ethernet interface and connect to the Compute Box
- Open the Web Client on your computer to access the WebLogic menu
- Write your program in the WebLogic menu

The following subsections will guide you through these steps.

5.2 Ethernet Interface setup

A proper IP address must be set for the Compute Box and the robot/computer to be able to use the Ethernet interface. There are three ways how it could be configured (using the DIP switch 3 and 4):

- **Auto mode** (factory default)

This is the easiest way of getting the IP addresses to be configured for both the Compute Box and the robot/computer. It is recommended to start with this mode, so this is the factory default setting.

- **Fixed IP mode** (192.168.1.1)

If the **Auto mode** does not work, use this mode to have a fixed IP for the Compute Box. This requires a manual IP address configuration for the robot/computer. (This mode could also be used to reset the IP address to a known value if the Compute Box become unreachable in **Advanced mode**.)

- **Advanced mode** (any static IP/subnet mask)

If the Fixed IP address (192.168.1.1) is already in use in your network or a different subnet needs to be configured, in this mode the IP address and subnet mask can be changed to any value. This also requires a manual IP address configuration for the robot/computer.



NOTE:

To change between modes, first change the DIP switches and then the Compute Box power needs to be cycled for the changes to take effect.

Auto mode



Use the factory default settings (DIP switch 3 and 4 in OFF position).

In this case, the Compute Box has both Dynamic Host Configuration Protocol (DHCP) client, and DHCP server enabled.

DHCP Client enabled means, Compute Box will automatically obtain ("get") IP address FROM the connected robot/computer if that is capable of assigning ("give") IP to the Compute Box.

DHCP Server enabled means, Compute Box will automatically assign ("give") IP address TO the connected robot/computer if that was configured to obtain ("get") IP address automatically.



NOTE:

The assigned IP range is 192.168.1.100-105 (with subnet mask 255.255.255.0).

If the Compute Box is used in a company network where a DHCP server is already in use, it is recommended to disable the DHCP server of the Compute Box by setting DIP switch 4 to the ON position.

If no IP was assigned to the Compute Box within a minute, it will automatically get a fallback IP address (192.168.1.1).



NOTE:

If the Compute Box was in **Advanced mode**, first reset the IP setting by switching to **Fixed IP mode** and then switch back to **Auto mode**.

Fixed IP mode

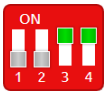

Set the DIP switch 3 and 4 in ON position and cycle the power for the changes to take effect.

In this case the IP address of the Compute Box is set to 192.168.1.1 (subnet mask is 255.255.255). Both the DHCP Client and Server options are disabled.

Make sure to set the robot/computer IP address manually. To have a proper communication the robot/computer IP address must be in the range of 192.168.1.2 - 192.168.1.254.

Example robot/computer setting:

IP address: 192.168.1.2

Subnet mask: 255.255.255.0

Other settings like Gateway, DNS Server, etc. could be kept empty or set to 0.0.0.0.

Advanced mode

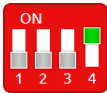

Set the DIP switch 3 in OFF and DIP switch 4 in ON position and cycle the power for the changes to take effect.

In this case the IP address of the Compute Box could be set to any value by using the Web Client. For more details see section **Configuration menu**.

In this mode, the DHCP server option is disabled.

Make sure to have a matching IP setting to your robot/computer network for a proper communication.



NOTE:

If the Compute Box become unreachable (due to improper or forgotten IP settings), switch to **Fixed IP mode** to reset the IP setting.

5.3 Web Client

To access the Web Client on your computer first the Ethernet interface needs to be set up to have a proper communication between your computer and the Compute Box. It is recommended to use Auto mode (for further details see section **Ethernet Interface setup**).

Then do the following steps:

- Connect the Compute Box to your computer with the supplied UTP cable.
- Power the Compute Box with the supplied power supply
- Wait one minute for the Compute Box LED to turn from blue to green.
- Open a web browser on your computer and type in the IP address of the Compute Box (factory default is 192.168.1.1).

The Sign-in page opens:

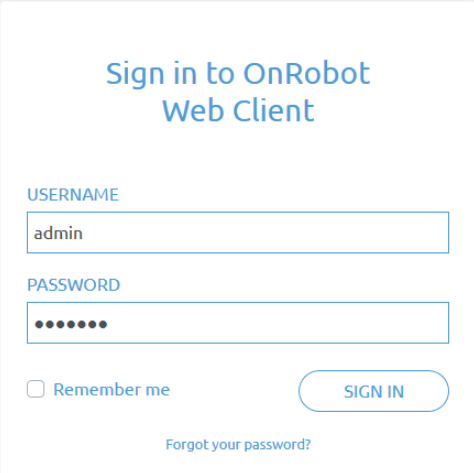

The screenshot shows the sign-in page for the OnRobot Web Client. The page has a white background with blue text and a light blue border. At the top, it says "Sign in to OnRobot Web Client". Below this, there are two input fields: "USERNAME" with the value "admin" and "PASSWORD" with a masked password of six dots. There is a "Remember me" checkbox which is unchecked, and a "SIGN IN" button. Below the button is a link that says "Forgot your password?". At the bottom of the form, there is a grey box with white text that reads: "Please sign in with the 'admin' username and the default password. You will be prompted to change the default password at first login."

The factory default administrator login is:

Username: admin

Password: OnRobot

Operation

For the first login a new password needs to be entered: (password must be at least 8 characters long)

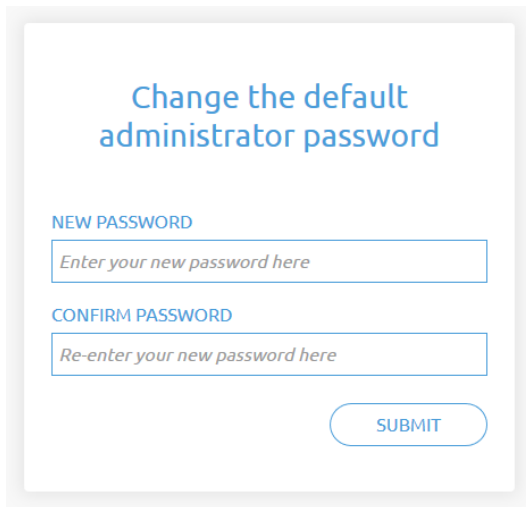

The screenshot shows a web form titled "Change the default administrator password". It contains two input fields: "NEW PASSWORD" with the placeholder text "Enter your new password here" and "CONFIRM PASSWORD" with the placeholder text "Re-enter your new password here". A "SUBMIT" button is located at the bottom right of the form.

Once logged in you can access top menus. Select **WebLogic** menu.

5.4 OnRobot WebLogic menu



There are two tabs to choose from:

- **Browser** - manage (import/export, etc.) the WebLogic programs
- **Program Editor** - create/edit or run WebLogic programs

In the following these two will be described.

5.4.1 Browser

This tab lists the WebLogic programs that are stored on the Compute Box.

- To create a new program, go to the **Program Editor** tab.
- To edit a stored program, click on the pencil  icon and it will be loaded in the **Program Editor**
- Any program can be deleted by clicking on the trash  icon.
- Programs can be exported to your computer by clicking on the down arrow  icon.
- Exported programs can be imported with the **Import** button.



NOTE:









The program name that are edited in the **Program Editor** is bolded.

OnRobot WebLogic

This page allows to browse/manage the OnRobot WebLogic programs. You can create new program and run it on the Editor tab. (To make your program run automatically on power-on, leave it running while powering the Compute Box off.)

Browser Program Editor

IMPORT You can import a program file from your computer.

PROGRAM NAME	ROWS	SIZE	
Program 1	2	2,742	  
Program 2	3	3,609	  
Program 3	13	20,480	  

5.4.2 Program Editor

This tab shows the currently edited WebLogic program.

WebLogic programs contains 1 or more "rows".

A row contains conditions (blue part) and commands (gray part) like this:

(If) DI1=1 → (Then) RG2-Width=77 (force=20N)

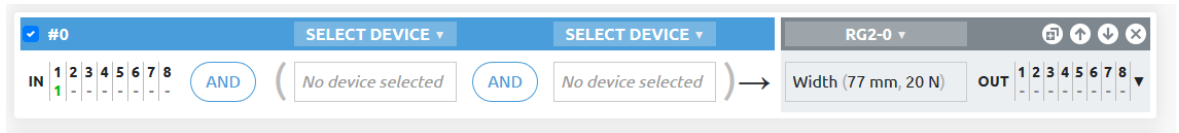

(If the robot sets the Digital Input 1 (DI1) of the Compute Box to high, **then** open the RG2 gripper to 77 mm.)

Another row in a program can be like this:

(If) DI1=0 → (Then) RG2-Width=20 (force=40N)

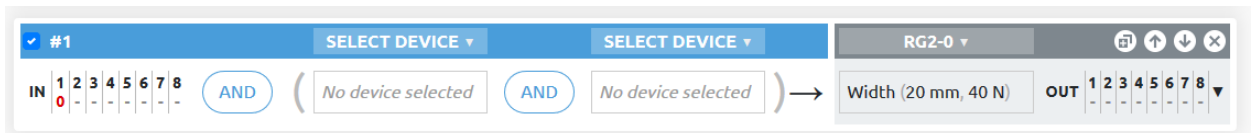

(If the robot sets the Digital Input 1 (DI1) of the Compute Box to low, **then** close the RG2 gripper to 20 mm.)

With the above two rows in a program an RG2/6 gripper could be operated (opened and closed) with a single Digital output of a robot, while the opening and closing width and force can be programmed to any value.

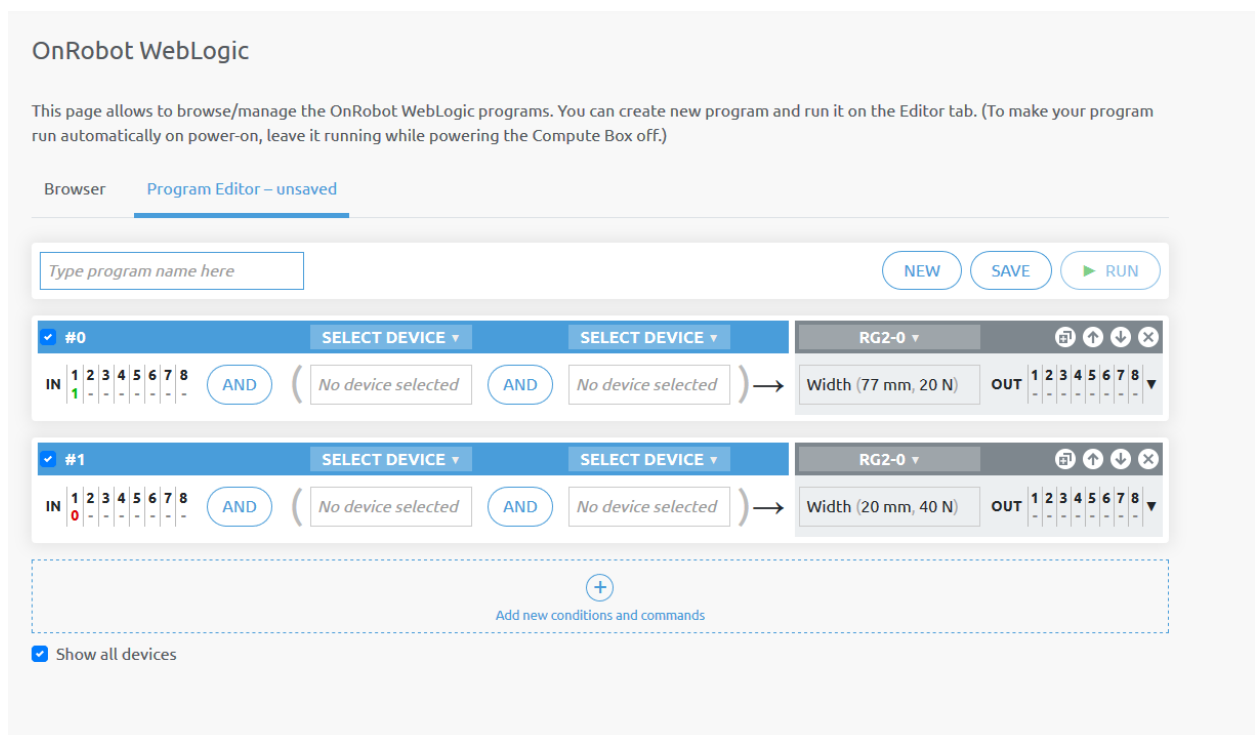

To execute a WebLogic program first make sure to enter a program name and click on the **Save** button to store it and then click on the **Run** button.



NOTE:

To make a program run automatically when the Compute Box is powered on just leave the program running while you power the Compute Box off.

To start a new program, click on the **New** button.

- To add a new row, click on the **Add new conditions and commands.**
- To delete a row, click on the icon.
- To move the row up or down click on the icons.



NOTE:

Conditions and commands are executed from the top to the bottom. Same commands at the bottom can override the ones at the top.

- To duplicate a row click on the icon.
- To disable a row (not to be executed) uncheck the checkbox # next to the row number.

The rows must have at least one condition and at least one command to be executed.

Conditions

Conditions are the input fields marked by blue.

There are two types of conditions:

- Digital Input type - like DI4=1
- Device specific value type - like HEX Fx > 10N

These types of conditions can be combined with AND or OR logic to form a more complex condition:

If (DI4=1) OR (HEX Fx > 10 N AND HEX Fx < 20N)

Condition is true if Fx is between 10N and 20N or robot has signaled high in Digital Input 4.

Digital inputs (DI1-DI8) can have the following three states: (click to cycle through the states)

- - Don't care (this bit is masked and will give true result for the bit)
- - give logic true if Input bit is low
- -give logic true if Input bit is high



NOTE:

If no Digital Input type of condition is needed set DI1-DI8 to don't care.

For Device specific values first set the **Select device** by clicking on the arrow icon.

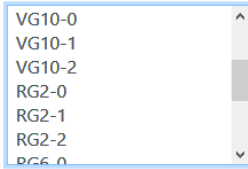

NOTE:

The list contains only the connected devices. If you would like to select a device that is not currently connected check the **Show all devices** checkbox.

For RG2/6, VG10/ VGC10 and Gecko there are three numbers after the device name:

- **0** - If the device is mounted on a Quick Changer or a HEX-E/H QC
- **1** - If the device is mounted on the Primary side of a Dual Quick Changer
- **2** - If the device is mounted on the Secondary side of a Dual Quick Changer



NOTE:

If a Device specific value type condition is not needed set it to **-- Not selected --** and it will give true result.

Commands

Commands are the input fields marked with gray.

There are two types of commands:

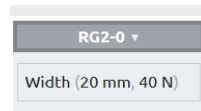

- Device specific value type - like (set RG2 width 77 mm and with force = 20N)
- Digital Output type - like DO4=1

1	2	3	4	5	6	7	8
-	-	-	1	-	-	-	-

 (set Digital Output 4 to logic high)



NOTE:

Both types are always executed so make sure that the not relevant part is always set to Don't change or **-- Not selected --**.

For Device specific value first set the **Select device** by clicking on the arrow icon.

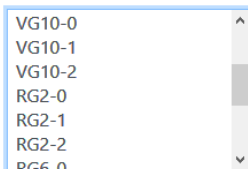

NOTE:

The list contains only the connected devices. If you would like to select a device that is not currently connected check the **Show all devices** checkbox.

For RG2/6, VG10/ VGC10 and Gecko there are three numbers after the device name:

- **0** - If the device is mounted on a Quick Changer or a HEX-E/H QC
- **1** - If the device is mounted on the Primary side of a Dual Quick Changer
- **2** - If the device is mounted on the Secondary side of a Dual Quick Changer

Digital outputs (DO1-DO8) can have the following three states: (click to cycle through the states)

- - Don't change
- - set the Output bit to logic low
- - set the Output bit to logic high

List of Device specific values

Gecko	34
HEX-E/H QC	35
RG2/6	35
RG2-FT	36
VG10 / VGC10	36



NOTE:

Each device has an **OnStart** condition that becomes True only once the device is connected or the program is started and then becomes immediately False. This can be used to detect if a device is connected or set any initial value on program start.

Gecko

Conditions	Description
Preload	Actual force applied to the pads [N] (below 50N it reads 0N)
Ultrasonic	Actual distance measured from the bottom of the gripper to the object.[mm]
Pad position	Actual position of the pads either In or Out
Pads worn	If a Grip was detected and then object distance becomes more than 18mm (without the pads being pulled IN) the object is lost so the Pads are Bad otherwise reads Good .
Busy	Pads are in motion
Grip	While the pads are OUT if the Preload force is reached and the object distance is less than 18mm, then Grip becomes TRUE otherwise FALSE . (resets to FALSE by pulling the pads IN)

Commands	Description
Pad position	To pull the pads In or push the pads Out
Preload threshold	To set the preload force limit that is used to detect a successful Grip . Available options are: 50N, 90N, 120N
Reset error logs	Clears the errors (e.g.: Pads worn)

HEX-E/H QC

Conditions	Description
Bias	TRUE if the sensor has been zeroed (biased).
F3D, T3D	$F3D = \sqrt{F_x^2 + F_y^2 + F_z^2}$ [N] $T3D = \sqrt{T_x^2 + T_y^2 + T_z^2}$ [Nm]
Fx, Fy, Fz, Tx, Ty, Tz	Actual force [N] and torque [Nm] values

Commands	Description
Bias	Set to TRUE to zero the F/T sensor signals (not permanent, will revert on power reset)

RG2/6

Conditions	Description
Width	Actual width of the gripper [mm]
Busy	True if the gripper is in motion (can only accept new commands when not busy)
Grip	Internal or external grip is detected.
Safety pressed	True if any of the gripper's safety switch is currently being pressed.
Safety triggered	True if any of the gripper's safety switch is triggered.

Commands	Description
Width	Set the gripper to a new width [mm] with a gripping force [N]
Fingertip offset	Set the fingertip offset from the inner side of the metal [mm]. Positive number means inward.
Power cycle	If safety switch stopped the gripper use this to get back to normal operation. Resets the tool power for a second. If another gripper is connected, that will also be powered off and powered on for a second. (Make sure that during power off no part to will be dropped.)

RG2-FT

Conditions	Description
Proximity (L,R)	Actual values of the left and right fingertip proximity sensors [mm]
Width	Actual width of the gripper [mm]
Busy	True if the gripper is in motion (can only accept new commands when not busy)
Grip	Internal or external grip is detected.
FT Bias	TRUE if the sensor has been zeroed (biased).
Left and Right F3D,T3D	F3D= $\sqrt{F_x^2 + F_y^2 + F_z^2}$ [N] where Fx, Fy, Fz are the fingertip sensor force components T3D= $\sqrt{T_x^2 + T_y^2 + T_z^2}$ [Nm] where Tx, Ty, Tz are the fingertip sensor torque components
Both F3D,T3D	The combined F3D and T3D acting on an object that the gripper gripped on

Commands	Description
Width	Set the gripper to a new width [mm] with a gripping force [N]
Bias	Set to TRUE to zero the F/T sensor signals (not permanent, will revert on power reset)

VG10 / VGC10

Conditions	Description
Actual vacuum A Actual vacuum B	Actual vacuum level [0-80%] for channel A and channel B

Commands	Description
Current limit	Set the current limit (0-1000mA), default is 500mA
Grip	Sets the vacuum level (0-80%) for channel A (param1) and channel B (param2)
Idle	Switch of the motor but keep the valve closed for channel A, B or A+B
Release	Opens the valve to quickly release the vacuum for channel A, B or A+B

6 Additional Software Options

6.1 Compute Box

6.1.1 Interfaces

There are two interface types that could be used:

- **Ethernet interface**

This interface can be used to access the Web Client that can be used to monitor, control, and update the grippers/devices. Furthermore, via this interface the OnRobot WebLogic can also be accessed to program the Digital I/O Interface.

- **Digital I/O interface**

This interface could be used to communicate via simple digital I/O lines with the robots. There are 8 digital input and 8 digital output that could be used. These inputs and outputs can be programmed through the OnRobot WebLogic that requires the Ethernet interface to be used (only for programming time).

6.1.2 Web Client

To access the Web Client on your computer first the Ethernet interface needs to be set up to have a proper communication between your computer and the Compute Box. It is recommended to use Auto mode (for further details see section **Ethernet Interface Setup**).

Then do the following steps:

- Connect the Compute Box to your computer with the supplied UTP cable.
- Power the Compute Box with the supplied power supply
- Wait one minute for the Compute Box LED to turn from blue to green.
- Open a web browser on your computer and type in the IP address of the Compute Box (factory default is 192.168.1.1).

The Sign-in page opens:

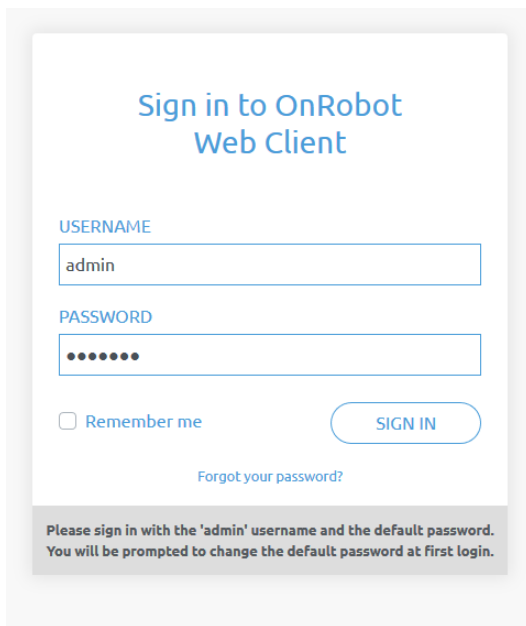

The factory default administrator login is:

Username: admin

Password: OnRobot

For the first login a new password needs to be entered: (password must be at least 8 characters long)

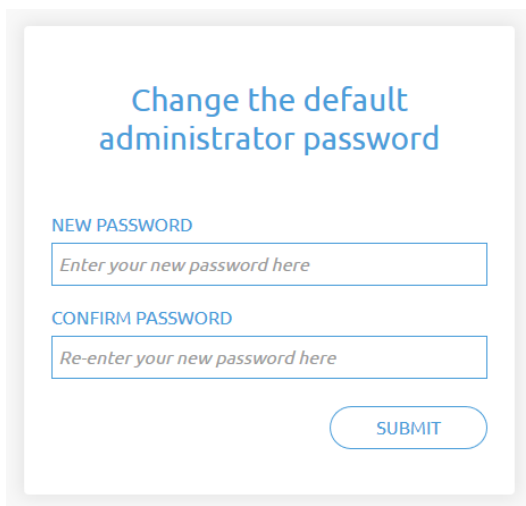



Once signed in the following top menus appear:



- **Devices** - Monitor and control the connected devices (e.g.: grippers)
- **Configuration** - Change the Compute Box's settings
- **WebLogic** - Program the Digital I/O interface through OnRobot WebLogic
- **Paths** - Import/export the recorded Paths (not available to all robots)
- **Update** - Update the Compute Box and the devices

Additional Software Options

-  - Account settings (e.g.: change password, add new user)
-  - Select the language of the Web Client

In the following, these menus will be described.

Devices menu

To control/monitor a device click on the **Select** button.

Please select from the detected device(s):



Compute Box

SELECT







HEX-E/H QC

SELECT



RG2

SELECT

	Gecko.....	40
	HEX-E/H QC.....	42
	RG2/6.....	43
	RG2-FT	45
	VG10 / VGC10.....	47

Gecko

Gecko Gripper

This page allows the device to be monitored and controlled. By navigating to the Device info tab the device status is shown. (Some functions might not be accessible without Admin permission.)

[Monitor and control](#) [Device info](#)

Actual values

Preload force	0 N
Object distance	1.76 mm
Pad position	Pads are out
Part detected	<input checked="" type="checkbox"/>
Busy	<input type="checkbox"/>

[RESET ERRORS](#)

Set values

PAD POSITION

[PADS OUT](#) [PADS IN](#)

PRELOAD THRESHOLD

50 N

There is a force and an ultrasonic distance sensor in the gripper. The actual values of these sensors are:

- **Preload** - the current forces acting on the pads (below 50N it displays 0N)
- **Object distance** - how far the object is from the bottom of the gripper

The state of the gripper could be:

- **Pad position**- Pads are either In or Out (out means ready for gripping)
- **Part detected** - the set preload force limit is reached, and object distance is < 18mm
- **Busy** - the pads are moving

The pads can be controlled by clicking on the **Out** and **In** buttons.

The **Preload threshold** value can be changed if higher preload force is required for a proper grip.

This value is only used to generate a proper **Part detected** signal.



NOTE:

Preload threshold value set on this page is not stored permanently and are restored to the default value (90N) on power reset.

If a part was detected and the object distance becomes $> 18\text{mm}$ (part is lost) BEFORE the pads are set to be IN (normal release) the **Pads worn** warning is displayed in the **Device info** tab.

To reset the warning:

- either click on the **RESET ERRORS** button
- or click on the **Out** button.

HEX-E/H QC

HEX-E/H QC

This page allows the device to be monitored and controlled. By navigating to the Device info tab the device status is shown. (Some functions might not be accessible without Admin permission.)

Monitor and control Device info

Force/Torque values

HEXHC001	
Fx (N)	-0.31
Fy (N)	0.16
Fz (N)	-1.00
Tx (Nm)	-0.008
Ty (Nm)	0.060
Tz (Nm)	0.003

ZERO

The force and torque values (**Fx,Fy,Fz** and **Tx,Ty,Tz**) are shown in N/Nm.

The **Zero** toggle switch can be used to zero the force and torque reading.



NOTE:

Zero value set on this page is not stored permanently and are restored to the default values on power reset.

RG2/6

RG2

This page allows the device to be monitored and controlled. By navigating to the Device info tab the device status is shown. (Some functions might not be accessible without Admin permission.)

Monitor and control Device info

States

- Busy
- Grip detected

Safety

RG2 GRIPPER	SWITCH 1	SWITCH 2
Pushed	<input type="radio"/>	<input type="radio"/>
Triggered	<input type="radio"/>	<input type="radio"/>

POWER CYCLE

Set width and force

FINGERTIP OFFSET

mm SAVE

WIDTH

51 mm

FORCE

20 N

Current width: 51 mm

The state of the gripper could be:

- **Busy** - the gripper is moving
- **Grip detected** - the set force limit is reached but the set width is not.

The status of the two safety switch shows:

- **Pushed** - the safety switch 1/2 is still being pushed
- **Triggered** - the safety switch 1/2 has been activated and gripper is stopped.

To recover from a Triggered state:

- Check if any of the safety switch is being pushed
- If yes, remove the object pushing the switch

Additional Software Options

- Click on **Power cycle** to power all devices off and then on to recover.

Fingertip offset must be set according to the current fingertips attached to the gripper. Offset is measured from the inner mating face of the bar metal fingertips. To save the value to the gripper permanently click **Save**.

The gripper can be controlled by adjusting the **Force** and **Width** value. First set the required gripping force and then adjust the width slider that will immediately control the gripper.

RG2-FT

RG2-FT

This page allows the device to be monitored and controlled. By navigating to the Device info tab the device status is (Some functions might not be accessible without Admin permission.)

Monitor and control Device info

Force/Torque and Proximity sensor values

LEFT / HEXSD329		HEXSD356 / RIGHT	
0 mm	<input type="text"/>	Proximity	<input type="text"/>
0.01		Fx (N)	-0.02
-0.02		Fy (N)	0.00
0.06		Fz (N)	0.08
0.000		Tx (Nm)	-0.001
-0.001		Ty (Nm)	0.001
0.000		Tz (Nm)	0.000

ZERO

PROXIMITY OFFSET

LEFT RIGHT

mm mm

Set width and force

WIDTH



FORCE



Current width: 0 mm

The force and torque values (**F_x, F_y, F_z** and **T_x, T_y, T_z**) are shown in N/Nm along with the Proximity sensor values (optical distance sensor built in the fingertip) are show in mm for the left and right fingertip sensor.

The **Zero** toggle switch can be used to zero the force and torque reading.



NOTE:

Zero value set on this page is not stored permanently and are restored to the default values on power reset.

The **Proximity Offset** can be used to calibrate the proximity reading. The calibration requires the following steps to be done:

- Write 0 mm to the **Left** and **Right** edit box and click on the **Save** button.
- Close the gripper fully (set the **Width** to 0) while you hold a white paper between the fingertips.

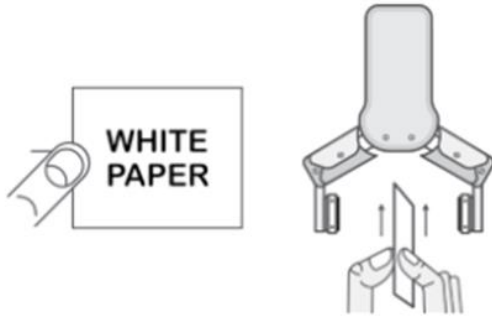

- Read the actual **Left** and **Right Proximity** values (e.g.: 19mm and 25mm)
- Write these values to the **Left** and **Right** edit boxes and click on the **Save** button to store it permanently.
- Open the gripper and the calibration is finished.



NOTE:

Setting the offsets too high may clip the proximity reading at 0 mm (negative distance is not shown). In case of clipping (reading 0 mm), try to decrease the offset values.

The gripper can be controlled by adjusting the **Force** and **Width** value. First set the required gripping force and then adjust the width slider that will immediately control the gripper.

VG10 / VGC10

VG10

This page allows the device to be monitored and controlled. By navigating to the Device info tab the device status is shown. (Some functions might not be accessible without Admin permission.)

Monitor and control Device info

Actual values

Power limit	500 mA
Channel A	0 kPa
Channel B	0 kPa

Set values

POWER LIMIT

CHANNEL A

CHANNEL B

Lock

The actual vacuum level for **Channel A** and **Channel B** can be seen in percentage (in the range of 0...80 kPa vacuum). The actual value of the **Power limit** is shown in mA.

The **Power limit** can be adjusted in the range of 0...1000mA with the slider.



NOTE:

The power limit set in this page is not stored permanently and always restored to the default value on power reset.

Higher power limit value means the required vacuum level is reached faster (higher airflow), but if it is set too fast overshoot may occur.

Low power limit may not be sufficient for higher percentage of vacuum and the target vacuum level may not be reached.

The **Channel A** and **Channel B** vacuum level can be set individually or in tandem by checking the **Lock** checkbox.

Make sure to set high enough vacuum before you grip and lift any object.

To release the gripped object, click on the **Release** button.

Configuration menu

Configuration

This page allows the configuration of the Compute Box.

CAUTION
 Incorrect settings may cause the device to lose network connectivity.

1. Digital input mode: NPN
2. Digital output mode: NPN
3. Compute Box IP setting is configured on this page.
4. DHCP server enabled: Compute Box tries to assign IP to the robot.

NETWORK SETTINGS

MAC address	b8:27:eb:0e:c9:a3
Network mode	Static IP ⌵
IP address	192.168.1.1 ✎
Subnet mask	255.255.255.0 ✎

SAVE

ETHERNET/IP SCANNER SETTINGS

IP address to connect to	_____
Origin-to-target instance id	1
Target-to-origin instance id	1
Configuration instance id	0
Requested packet interval (ms)	8

SAVE

COMPUTE BOX SETTINGS

Display name

✎

SAVE

Network settings:

The **MAC address** is a world-wide unique identifier that is fixed for the device.

The **Network mode** drop-down menu can be used to decide if the Compute Box will have a static or a dynamic IP address:

- If it is set to **Dynamic IP**, the Compute Box expects an IP address from a DHCP server. If the network that the device is connected to has no DHCP server, then the fixed 192.168.1.1 IP is used for the device (after 60 seconds of timeout).
- If it is set to **Static IP**, then a fixed IP address and subnet mask must be set.
- If it is set to **Default Static IP**, the fixed IP revert to the factory default and cannot be changed.

After all parameters are set, click on the **Save** button to store the new values permanently. Wait 1 minute and reconnect to the device using the new settings.

Compute Box settings:

In case, more than one Compute Box is used within the same network, for identification purpose any user specific name can be entered to the **Display name**.

EtherNet/IP scanner settings:



NOTE:

This is a special option of the EtherNet/IP connection for some robots.

In case when the robot is the Adapter and the Compute Box needs to be the Scanner the following addition information is required for the communication:

- **IP address to connect to** - the robot IP address
- **Origin-to-target instance id** - refer to the robot's EtherNet/IP manual (Scanner mode)
- **Target-to-origin instance id** - refer to the robot's EtherNet/IP manual (Scanner mode)
- **Configuration instance id** - refer to the robot's EtherNet/IP manual (Scanner mode)
- **Requested packet interval (ms)** - RPI value in ms (minimum 4)

Check the checkbox and the Compute Box will try to automatically connect to the robot (via the given IP address).

Paths menu



NOTE:

The Path feature may not be available to your robot type.

This page can be used to import, export, and delete the previously recorded paths. In this way a Path can be copied to a different Compute Box.

Manage paths

This page allows uploading and downloading path files.

[IMPORT](#) You can import a path file from your computer.

PATH NAME	SIZE (IN BYTES)		
1539	1,692	↓	🗑️
3923	1,972	↓	🗑️
3924	1,972	↓	🗑️

To import a previously exported Path (.ofp file) click on **Import** and browse for the file.

The available Paths are listed at the end of the page. Any paths can be exported and downloaded as a .ofp file or permanently deleted to free up the list if a path is not needed anymore.



NOTE:

Always make sure that you do not delete any path that is currently in use in any of your robot programs. Otherwise the path will need to be re-recorded, since the delete operation cannot be undone.

The Compute Box can store up to 100 Mbytes of paths that is roughly equal to 1000 hours of recordings.

Update menu

This page can be used to update the software on the Compute Box and the firmware on the devices.

Update

This page allows updating the software and firmware.

!

CAUTION

Installing updates may take several minutes to complete. Please do not power off or unplug your Compute Box or any of the connected devices during the update process.

SOFTWARE

No update file selected yet...
BROWSE

[Click here to download the result of the last update.](#)

FIRMWARE

COMPONENTS	CURRENT VERSION	REQUIRED VERSION	
Compute Box (CBOX_RPT)			
Firmware	150	150	✓
HEX-E/H QC (HEXEX006)			
Firmware	208	208	✓

UPDATE

✓ Up-to-date
 ↻ Update required
 ✗ Downgrade not supported

Start the software update by clicking on the **Browse** button to browse for the .cbu software update file.

Then the **Browse** button will turn to **Update**.

Click on that **Update** button to start the software update process:

Update in progress, please wait...

This may take several minutes to complete.

CLOSE



CAUTION:

During the update process (takes about 5-10 minutes) DO NOT unplug any device or close the browser window. Otherwise the updated device could be damaged.

If the update is finished and was successful, the following message is shown:

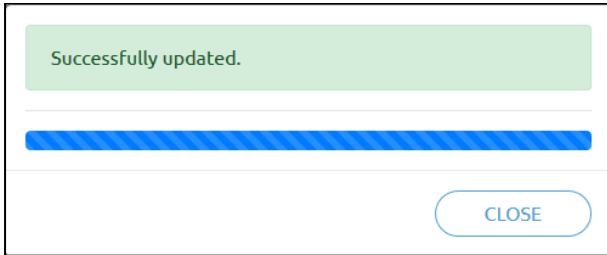

Now disconnect the device and use it as usual.



NOTE:

If the software update failed, please contact your distributor.

The firmware update is only required when any of the components  is out of date.

To start the firmware update, click on **UPDATE** button in the firmware section of the page.

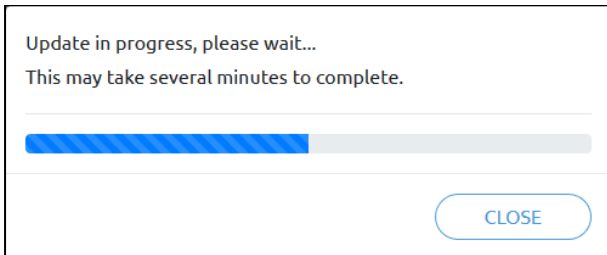

CAUTION:

During the update process (takes about 5-10 minutes) DO NOT unplug any device or close the browser window. Otherwise the updated device could be damaged.

If the update is finished and was successful, the following message is shown:

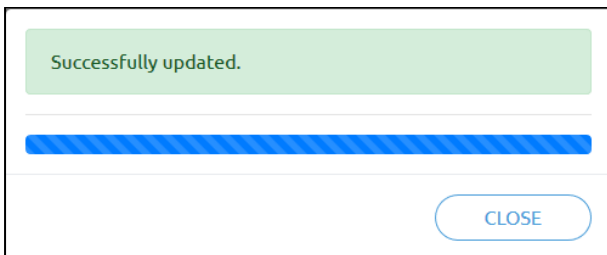

Now disconnect the device and use it as usual.



NOTE:

If the update is failed, please contact your distributor.

 **Account settings**

This menu can be used to:

- See the currently sign-id user
- Go to **Account settings**
- Sign-out

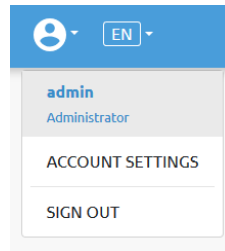

Account settings:

This page has two tabs:

- **My profile** - to see and update the currently logged in users profile (e.g.: change password)
- **Users** - to manage users (e.g.: add/remove/edit)

On the **My profile** tab to change any profile data (e.g.: password) click on the **Update profile** button.

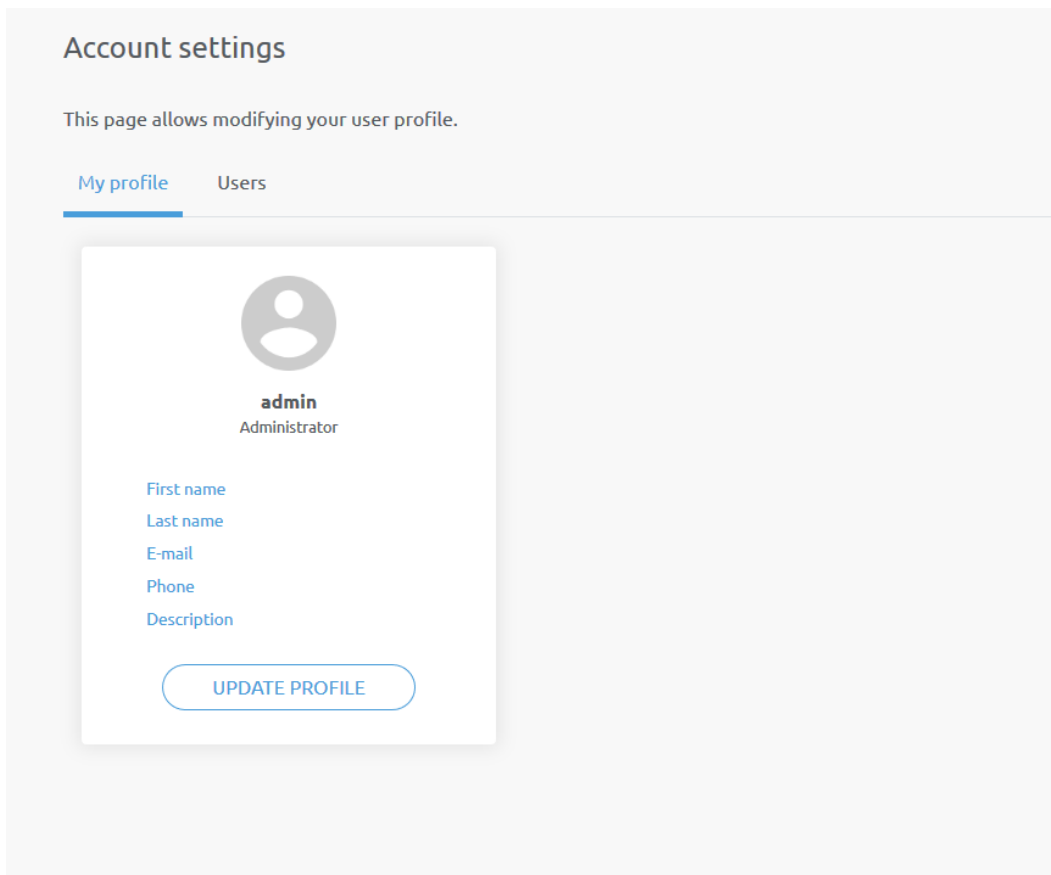

On the **Users** tab click on the **Add new user** button to add more users:

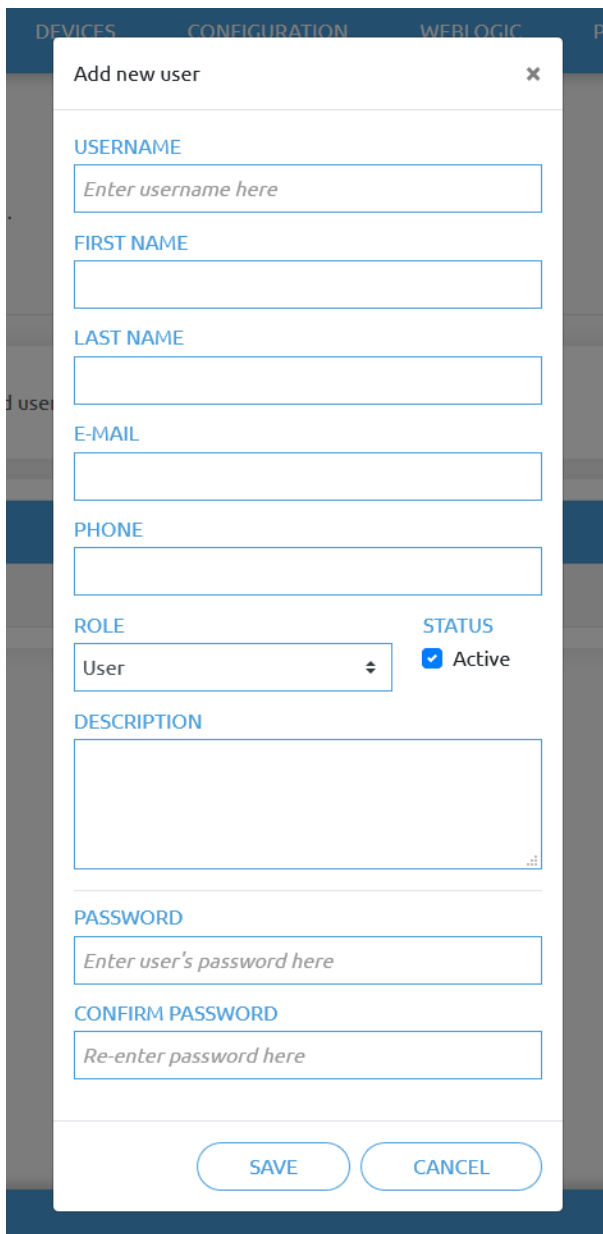

There are three user levels:

- Administrator
- Operator
- User

Fill in the user information and click **Save**.



Later on to change any user information just click on the edit  icon.

Account settings

This page allows modifying your user profile.

My profile Users

[ADD NEW USER](#) You can add user on your network to monitor and control the devices.













USERNAME	ROLE	FIRST NAME	LAST NAME	E-MAIL	PHONE	ACTIVE	
admin	Administrator					<input checked="" type="checkbox"/>	
operator	User					<input checked="" type="checkbox"/>	 

To prevent a user to sign-in either could be:

- deactivated by changing its **Active** status in the edit mode
- or removed by clicking the delete  icon.

7 Hardware Specification

7.1 Technical sheets

 Gecko.....	57
 HEX-E QC.....	60
 HEX-H QC.....	62
 Quick Changer	64
 Quick Changer for I/O	64
 Dual Quick Changer	64
 Quick Changer - Tool side.....	64
 RG2-FT	66
 RG2.....	71
 RG6.....	74
 VG10.....	77
 VGC10.....	84

Gecko

General Properties					Unit
Gripper					
Workpiece Material	Polished Steel	Acrylic	Glass	Sheet Metal	
Maximum payload (x2 safety factor)	6.5 14.3	6.5 14.3	5.5 12.1	5.5 12.1	[kg] [lb]
Preload required for max adhesion	140				[N]
Detachment time	300				[msec]
Holds workpiece on power loss?	yes				
Pads					
Change-out interval	150 000 to 200 000 cycles for HIGH preload 200 000 to 250 000 cycles for LOW preload				[cycles]
Manual Cleaning	Isopropyl alcohol and lint free cloth				
Robotic cleaning system	Cleaning Station				
Robotic cleaning interval and % recovery	Refer to Cleaning Station User Guide				
Sensors					
	Pre-load sensor		Ultrasonic Range sensor		
Range	45 [N] 9 [lb]	140 [N] 31 [lb]	0	260 [mm] 10 [inch]	[N][mm] [lb][inch]
Error	7%		2%		
IP Classification	42				
Dimensions (HxW)	187 x 146 7.3 x 5.7				[mm] [inch]
Weight	2.85 6.3				[kg] [lb]



NOTE:

Avoid preloading the gripper with an inverted robot or in non-vertical loading conditions. If preloaded whilst inverted, preload sensor will not meet typical performance standards.

Operating Conditions	Minimum	Typical	Maximum	Unit
Temperature	0 32	- -	50 122	[°C] [°F]
Surface Characteristics*	Matte finish	Highly polished	-	

* Smoother surfaces require less preload force for a desired payload force.

Specification or Feature	Target value
Parts Presence Sensing	Yes (Ultrasonic)
Pad Material	Proprietary silicone blend
Wear Properties	Depends on surface roughness and preload
Pad Attachment Mechanism	Magnetic
Change-out interval	150000 – 200000 for HIGH PRELOAD 200000 – 250000 for LOW PRELOAD
Cleaning system	Cleaning station
Cleaning interval and % recovery	See Cleaning Station Manual

Effectiveness on Different Materials

The Gecko Gripper is best suited for smooth, low surface roughness substrates that are generally flat, stiff, and rigid. For other materials, the Gecko Gripper’s effectiveness drops depending the stiffness and roughness of the picking surface. The table below shows a relationship between rigid and flexible substrates, surface finish, payload and the required preload to pick up said substrate . For example, if the customer knows that their part/substrate is rigid, with a mirror-like finish and weighs 2kg, the preload required to pick up the part/substrate is a medium-level preload.

Flexibility	Surface finish	Payload (kg)	Required Preload
Rigid	Mirror-like finish	0 to 2	Low
		2 to 4	Medium
		4 to 6	High
	Smooth	0 to 2	Medium
		2 to 4	High
		4 to 6	N/A
	Matte	0 to 2	High
		2 to 4	N/A
		4 to 6	N/A
Flexible	Mirror-like finish	0 to 2	Medium
		2 to 4	High
		4 to 6	N/A
	Smooth	0 to 2	High
		2 to 4	N/A
		4 to 6	N/A
	Matte	0 to 2	N/A
		2 to 4	N/A
		4 to 6	N/A

To further elaborate the significance between preload and payload, the table below shows visual matrix that displays the capability of the gecko gripper to pick up different materials with varying stiffness and roughness, at three different preload values (low 40N, medium 90N, high 140N).

Stiffness	Roughness	Example of material	Preload - 140N						Preload - 90N						Preload - 40N					
			Payload [kg]						Payload [kg]						Payload [kg]					
			0.1	0.5	1	2	4	6	0.1	0.5	1	2	4	6	0.1	0.5	1	2	4	6
1	1	Mylar	✓	✓	✓	*			✓	✓	*			✓	*					
5	1	Transparency sheet	✓	✓	✓	✓	*		✓	✓	*			✓	*					
10	1	Polished mirror-like steel, solar panel	✓	✓	✓	✓	✓	✓	✓	✓	✓	✓	✓	*	✓	✓	✓	✓	*	
1	5	Cling film, ziploc bags	✓	✓	*				✓	*				✓	*					
5	5	Glossy carboard (cereal box)	✓	✓	*				✓	*				✓	*					
10	5	Printed circuit board	✓	✓	✓	✓	*		✓	✓	*			✓	*					
1	10	Laminating plastic / film	*																	
5	10	Corrugated cardboard																		
10	10	Sandblasted aluminum																		

✓ the gripper can easily pick up the material

* the gripper can pick up the material in some cases (requires caution and testing to verify)

Nothing the gripper cannot pick up this type of material.



NOTE:

This table is to be utilized as a guide to better understand the payload capacity and substrate type for the Gecko Gripper.

The criteria for stiffness and roughness is a basic scale from 1-10, here are the benchmarks used to determine the values.

Stiffness	Description	Example
1	Flexible	Fabric
5	Semi-flexible	Cardboard
10	Stiff	Metal

Roughness	Description	Example	RMS Value
1	Polished/Smooth	Polished Metal	0.1 micron
5	Textured	Carboard	7 microns
10	Rough	Sandblasted Metal	28 microns

HEX-EQC

General Properties	6-Axis Force/Torque Sensor				Unit
	Fxy	Fz	Txy	Tz	
Nominal Capacity (N.C)	200	200	10	6.5	[N] [Nm]
Single axis deformation at N.C (typical)	± 1.7 ± 0.067	± 0.3 ± 0.011	± 2.5 ± 2.5	± 5 ± 5	[mm] [°] [inch] [°]
Single axis overload	500	500	500	500	[%]
Signal noise* (typical)	0.035	0.15	0.002	0.001	[N] [Nm]
Noise-free resolution (typical)	0.2	0.8	0.01	0.002	[N] [Nm]
Full scale nonlinearity	< 2	< 2	< 2	< 2	[%]
Hysteresis (measured on Fz axis, typical)	< 2	< 2	< 2	< 2	[%]
Crosstalk (typical)	< 5	< 5	< 5	< 5	[%]
IP Classification	67				
Dimensions (H x W x L)	50 x 71 x 93 1.97 x 2.79 x 3.66				[mm] [inch]
Weight (with built-in adapter plates)	0.347 0.76				[kg] [lb]

* Signal noise is defined as the standard deviation (1 σ) of a typical one second no-load signal.

Operating Conditions	Minimum	Typical	Maximum	Unit
Power supply	7	-	24	[V]
Power consumption	-	-	0.8	[W]
Operating temperature	0 32	- -	55 131	[°C] [°F]
Relative humidity (non-condensing)	0	-	95	[%]
Calculated MTBF (operating life)	30.000	-	-	[Hours]

Complex loading

During single-axis loading, the sensor can be operated up to its nominal capacity. Above the nominal capacity the reading is inaccurate and invalid.

During complex loading (when more than one axis is loaded) the nominal capacities are reduced. The following diagrams show the complex loading scenarios.

The sensor cannot be operated outside of the Normal Operating Area.

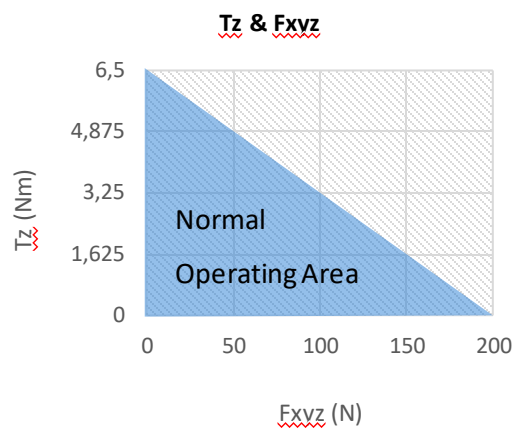
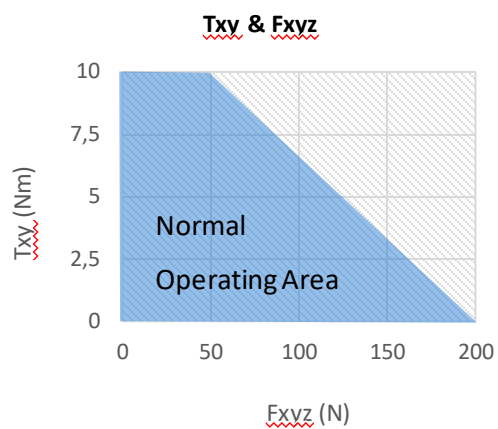

HEX-H QC

General Properties	6-Axis Force/Torque Sensor				Unit
	Fxy	Fz	Txy	Tz	
Nominal Capacity (N.C)	200	200	20	13	[N] [Nm]
Single axis deformation at N.C (typical)	± 0.6 ± 0.023	± 0.25 ± 0.009	± 2 ± 2	± 3.5 ± 3.5	[mm] [°] [inch] [°]
Single axis overload	500	400	300	300	[%]
Signal noise* (typical)	0.1	0.2	0.006	0.002	[N] [Nm]
Noise-free resolution (typical)	0.5	1	0.036	0.008	[N] [Nm]
Full scale nonlinearity	< 2	< 2	< 2	< 2	[%]
Hysteresis (measured on Fz axis, typical)	< 2	< 2	< 2	< 2	[%]
Crosstalk (typical)	< 5	< 5	< 5	< 5	[%]
IP Classification	67				
Dimensions (H x W x L)	50 x 71 x 93 1.97 x 2.79 x 3.66				[mm] [inch]
Weight (with built-in adapter plates)	0.35 0.77				[kg] [lb]

* Signal noise is defined as the standard deviation (1 σ) of a typical one second no-load signal.

Operating Conditions	Minimum	Typical	Maximum	Unit
Power supply	7	-	24	[V]
Power consumption	-	-	0.8	[W]
Operating temperature	0 32	- -	55 131	[°C] [°F]
Relative humidity (non-condensing)	0	-	95	[%]
Calculated MTBF (operating life)	30.000	-	-	[Hours]

Complex loading

During single-axis loading, the sensor can be operated up to its nominal capacity. Above the nominal capacity the reading is inaccurate and invalid.

During complex loading (when more than one axis is loaded) the nominal capacities are reduced. The following diagrams show the complex loading scenarios.

The sensor cannot be operated outside of the Normal Operating Area.

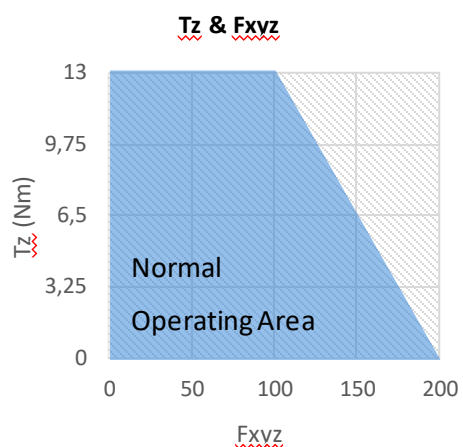
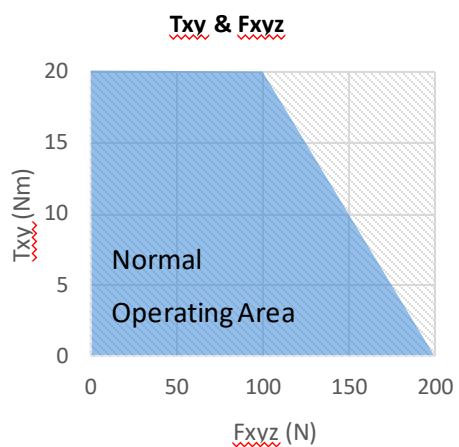

Quick Changer
 Quick Changer for I/O
 Dual Quick Changer
 Quick Changer - Tool side

If not specified, the data represent the combination of the different Quick Changer types/sides.

Technical data	Min	Typical	Max	Units
Permissible force*	-	-	400*	[N]
Permissible torque*	-	-	50*	[Nm]
Rated payload*	-	-	20* 44	[kg] [lbs]
Repeatability	-	-	±0.02	[mm]
IP Classification	64			
Operating life (Tool change)	-	5.000	-	[cycles]
Operating life (Robot operation)	10	-	-	[M cycles]



* See load capacity graph below.

	Quick Changer	Quick Changer for I/O	Dual Quick Changer	Quick Changer - Tool Side	Units
Weight	0.06	0.093	0.41	0.14	[kg]
	13.22	2.05	90.39	30.86	[lb]
Dimensions	See Mechanical dimension section				

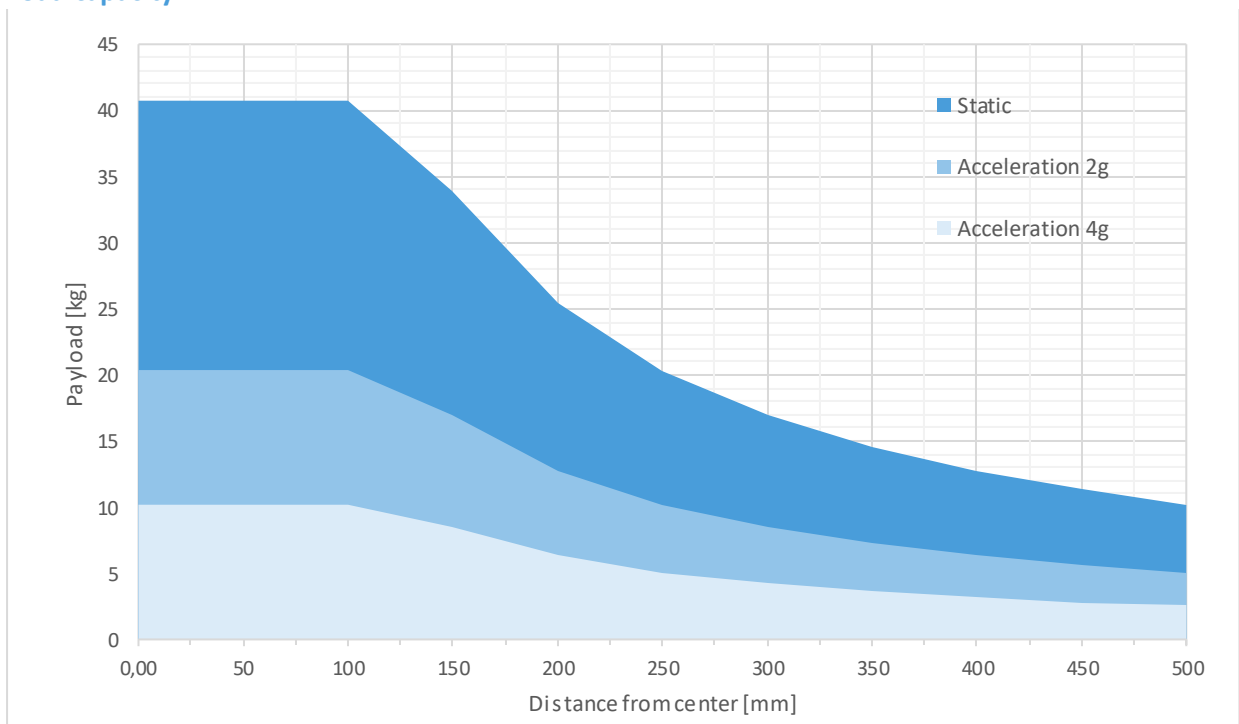
Load capacity



RG2-FT

General Properties	Min	Typical	Max	Units
Payload Force Fit  2 Kg	- -	- -	2 4.4	[kg] [lb]
Payload Form Fit  4 Kg	- -	- -	4 8.8	[Kg] [lb]
Total stroke (adjustable)	0 0	- -	100 3.93	[mm] [inch]
Finger position resolution	- -	0.1 0.004	- -	[mm] [inch]
Repetition accuracy	- -	0.1 0.004	0.2 0.007	[mm] [inch]
Reversing backlash	0.2 0.007	0.4 0.015	0.6 0.023	[mm] [inch]
Gripping force (adjustable)	3	-	40	[N]
Gripping speed*	55	110	184	[mm/s]
Gripping time**	0.04	0.07	0.11	[s]
Adjustable bracket tilting accuracy	-	< 1	-	°
Ambient operating temperature	5	-	50	[°C]
Storage temperature	0	-	60	[°C]
Motor	Integrated, electric BLDC			
IP Classification	IP54			
Dimensions	219 x 149 x 49 8.6 x 5.9 x 1.9			[mm] [inch]
Product weight	0.98 2.16			[kg] [lb]

* see speed table 65

** based on 8mm total movement between fingers. The speed is linearly proportional to the force. For more details see speed table on page 65.

Force Sensor Properties	Fxy	Fz	Txy	Tz	Units
Nominal capacity (N.C.)	20	40	0.7	0.5	[N] [Nm]
Single axis overload	200	200	200	200	[%]
Noise free resolution	0.1	0.4	0.008	0.005	[N] [Nm]
Single axis deformation at N.C.	0.4 0.015	0.1 0.04	2	5	[mm] [°] [inch] [°]
Full scale nonlinearity Temperature compensation	< 2				[%]

Proximity Sensor Properties	Min	Typical	Max	Units
Sensing range	0	-	100	[mm]
	0	-	3.93	[inch]
Precision	-	2	-	[mm]
	-	0.078	-	[inch]
Non-linearity*	-	12	-	[%]

* the non-linearity refers to the max value and depends on the object properties (e.g. surface type and color)

Operating Conditions	Minimum	Typical	Maximum	Unit
Power requirement (PELV)	24	-	24	[V]
Power consumption	6.5	-	22	[W]
Operating temperature	0	-	55	[°C]
	32	-	131	[°F]
Relative humidity (non-condensing)	0	-	95	[%]
Calculated MTBF (operating life)	30.000	-	-	[Hours]

Proximity sensor typical accuracy

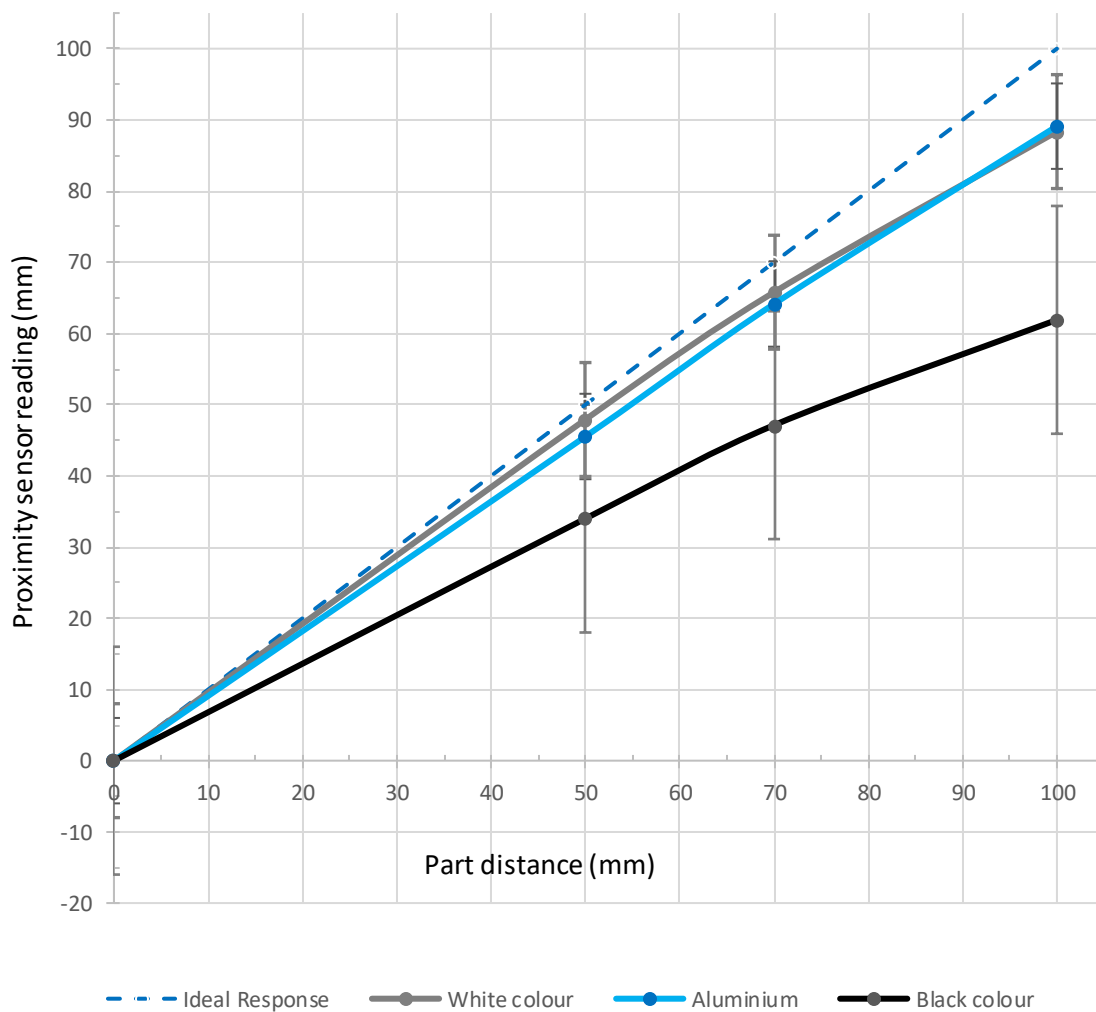

RG2-FT Gripping Speed Graph

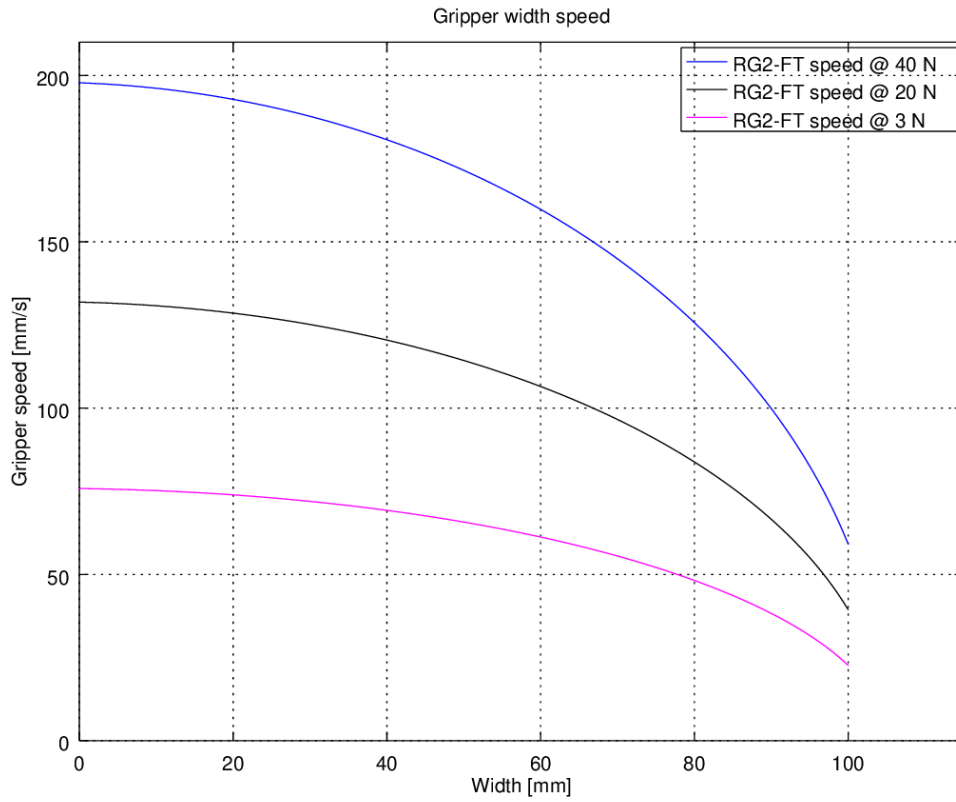

Gripper Working Range

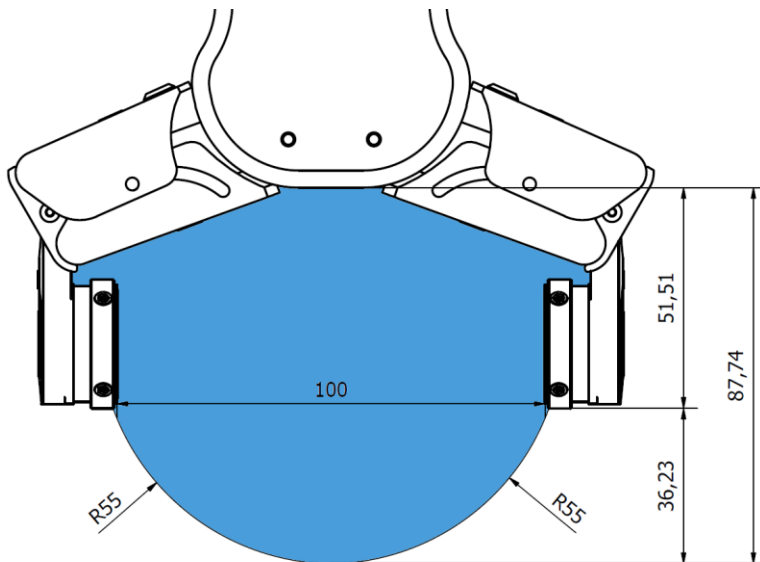

The dimensions are in millimeters.

Fingertips

The standard fingertips can be used for many different workpieces. If custom fingertips are required, they can be made to fit the Gripper fingers.

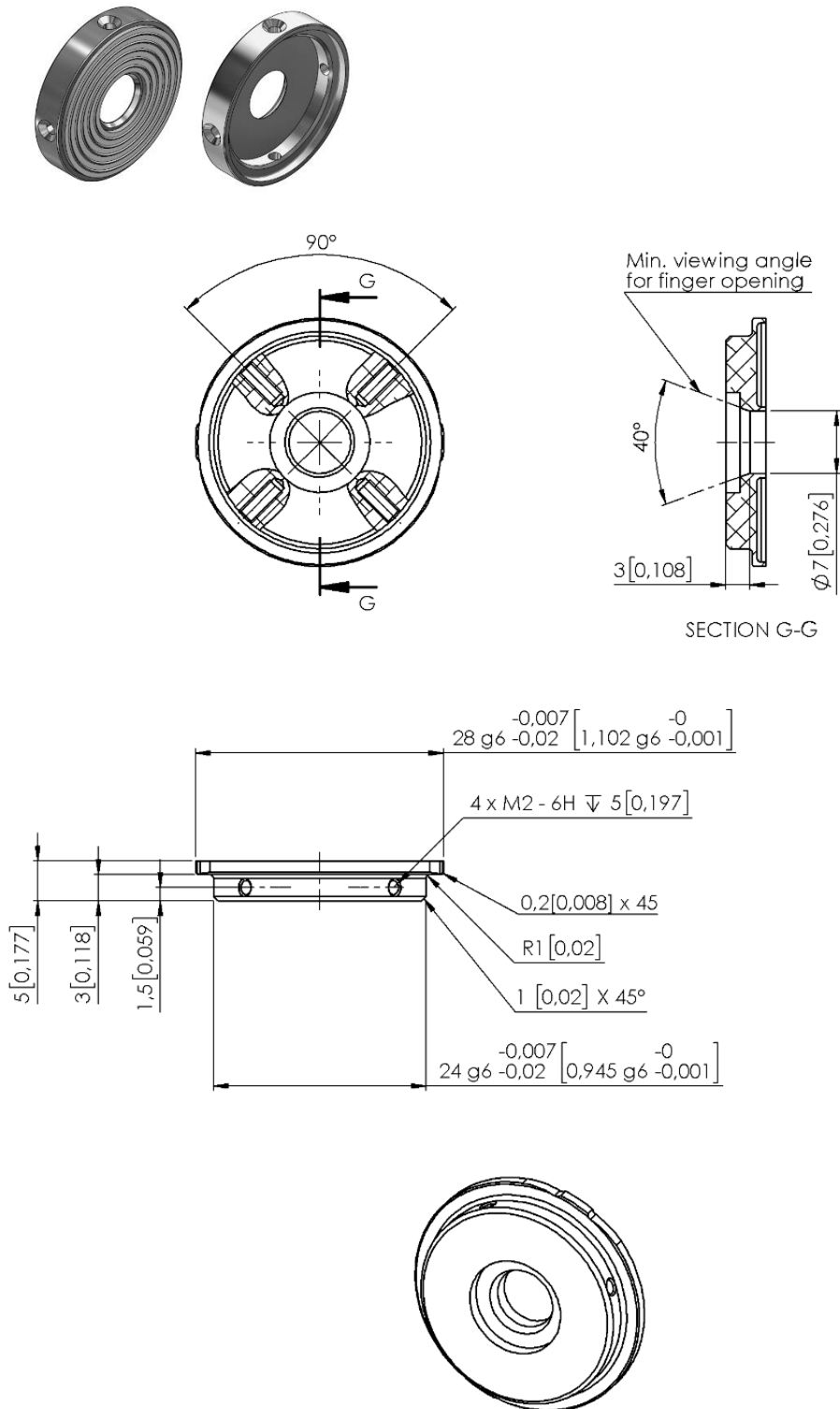

Dimensions of the Gripper's finger, in millimeters.



NOTE:

During the fingertip design, the following shall be considered to maintain optimal performance:

Clear optical path for the proximity sensors

Protect the proximity sensors from direct sunlight or strong light source

Avoid dust and liquid penetration



WARNING:

The proximity sensors are sensitive parts and shall be protected against:

Direct strong light (such as directional laser sources)

Direct high temperature

Mechanical contacts in any case

Expose to any liquid or fine conductive dust





NOTE:

Please clean regularly the proximity sensor surface with low pressure compressed air (<5 bar) from a 5 cm distance. For stronger contamination use isopropyl alcohol with a soft cotton swab to keep it clean.

Finger Thickness

The default fingertips are considered while the finger thickness has been set and could not be changed in the software. In case when custom fingertips are used, the user should manually compensate for the difference in the finger thickness.

RG2

General Properties	Minimum	Typical	Maximum	Unit
Payload Force Fit 	-	-	2 4.4	[kg] [lb]
Payload Form Fit 	-	-	5 11	[kg] [lb]
Total stroke (adjustable)	0 0	- -	110 4.33	[mm] [inch]
Finger position resolution	- -	0.1 0.004	- -	[mm] [inch]
Repetition accuracy	- -	0.1 0.004	0.2 0.007	[mm] [inch]
Reversing backlash	0.1 0.004	- -	0.3 0.011	[mm] [inch]
Gripping force (adjustable)	3	-	40	[N]
Gripping force deviation		±25		%
Gripping speed*	38	-	127	[mm/s]
Gripping time**	0.06	-	0.21	[s]
Adjustable bracket tilting accuracy	-	< 1	-	°
Storage temperature	0 32	- -	60 122	[°C] [°F]
Motor	Integrated, electric BLDC			
IP Classification	IP54			
Dimensions	213 x 149 x 36 8.3 x 5.9 x 1.4			[mm] [inch]
Weight	0.78 1.72			[kg] [lb]

*See table on the next page

** based on 8mm total movement between fingers. The speed is linearly proportional to the force. For more details see speed table on next page.

Operating Conditions	Minimum	Typical	Maximum	Unit
Power supply	20	24	25	[V]
Current consumption	70	-	600*	[mA]
Operating temperature	5 41	- -	50 122	[°C] [°F]
Relative humidity (non-condensing)	0	-	95	[%]
Calculated MTBF (operating life)	30.000	-	-	[Hours]

* Current spikes up to 3A (max 6mS) may occur during the release action.

RG2 Gripping Speed Graph

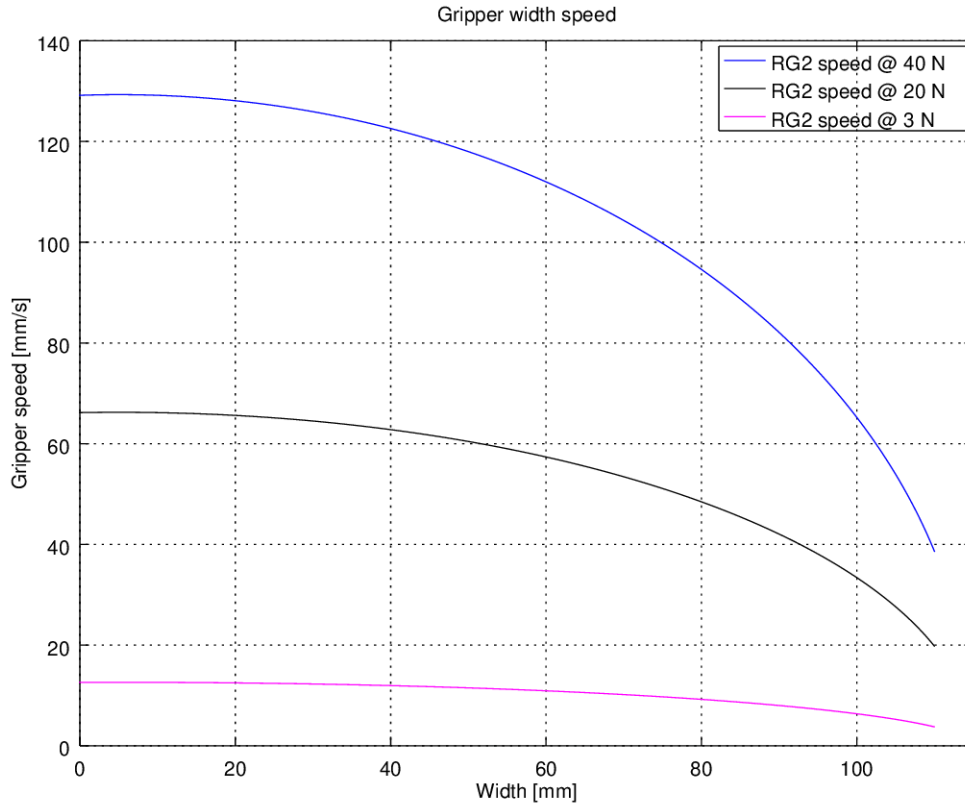

RG2 Work Range

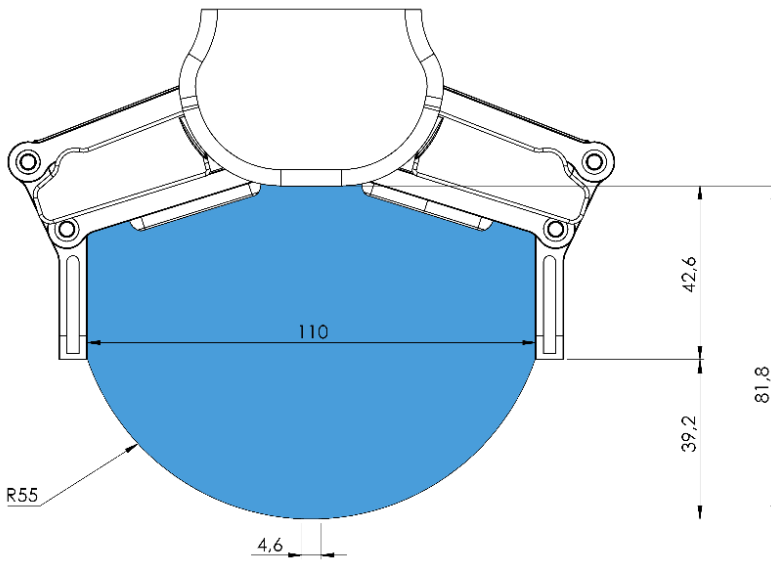

Gripping on long objects can unintentionally activate the Safety switches. The maximum workpiece height (calculated from the end of the fingertips) is dependent on the gripping width (w). For various width values the height (h) limit is given below:

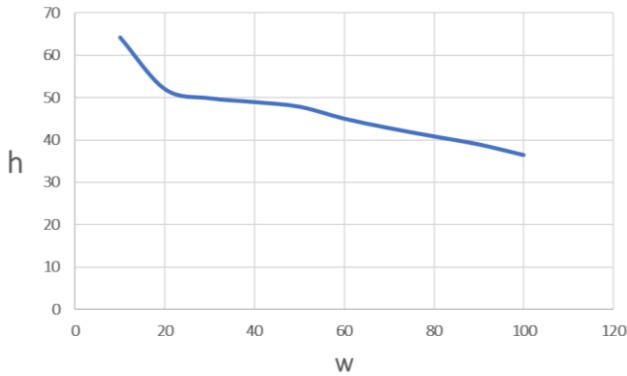

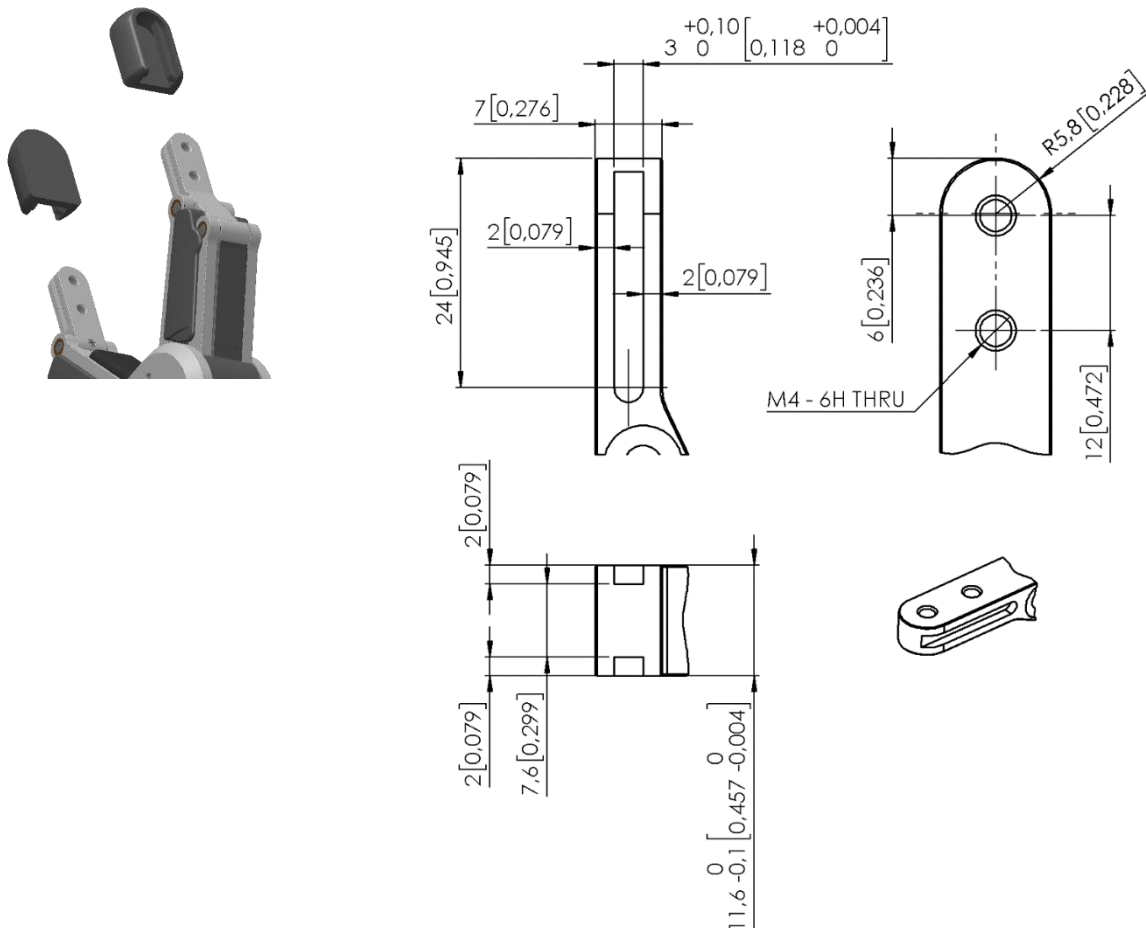

Fingertips

The standard fingertips can be used for many different workpieces. If custom fingertips are required, they can be made to fit the Gripper's fingers according to the dimensions (mm) shown below:



RG6

General Properties	Minimum	Typical	Maximum	Unit
Payload Force Fit 	-	-	6 13.2	[kg] [lb]
Payload Form Fit 	-	-	10 22.04	[Kg] [lb]
Total stroke (adjustable)	0 -	- -	160 6.3	[mm] [inch]
Finger position resolution	- -	0.1 0.004	- -	[mm] [inch]
Repetition accuracy	- -	0.1 0.004	0.2 0.007	[mm] [inch]
Reversing backlash	0.1 0.004	- -	0.3 0.011	[mm] [inch]
Gripping force (adjustable)	25	-	120	[N]
Gripping force deviation		±25		%
Gripping speed*	51	-	160	[mm/s]
Gripping time**	0.05	-	0.15	
Adjustable bracket tilting accuracy		< 1		°
Storage temperature	0 32		60 122	[°C] [°F]
Motor	Integrated, electric BLDC			
IP Classification	54			
Dimensions	262 x 212 x 42 10.3 x 8.3 x 1.6			[mm] [inch]
Weight	1.25 2.76			[kg] [lb]

*See table on the next page

** based on 8mm total movement between fingers. The speed is linearly proportional to the force. For more details see speed table on next page.

Operating Conditions	Minimum	Typical	Maximum	Unit
Power supply	20	24	25	[V]
Current consumption	70	-	600*	[mA]
Operating temperature	5 41	- -	50 122	[°C] [°F]
Relative humidity (non-condensing)	0	-	95	[%]
Calculated MTBF (operating life)	30.000	-	-	[Hours]

*Current spikes up to 3A (max 6mS) may occur during the release action.

RG6 Gripping Speed Graph

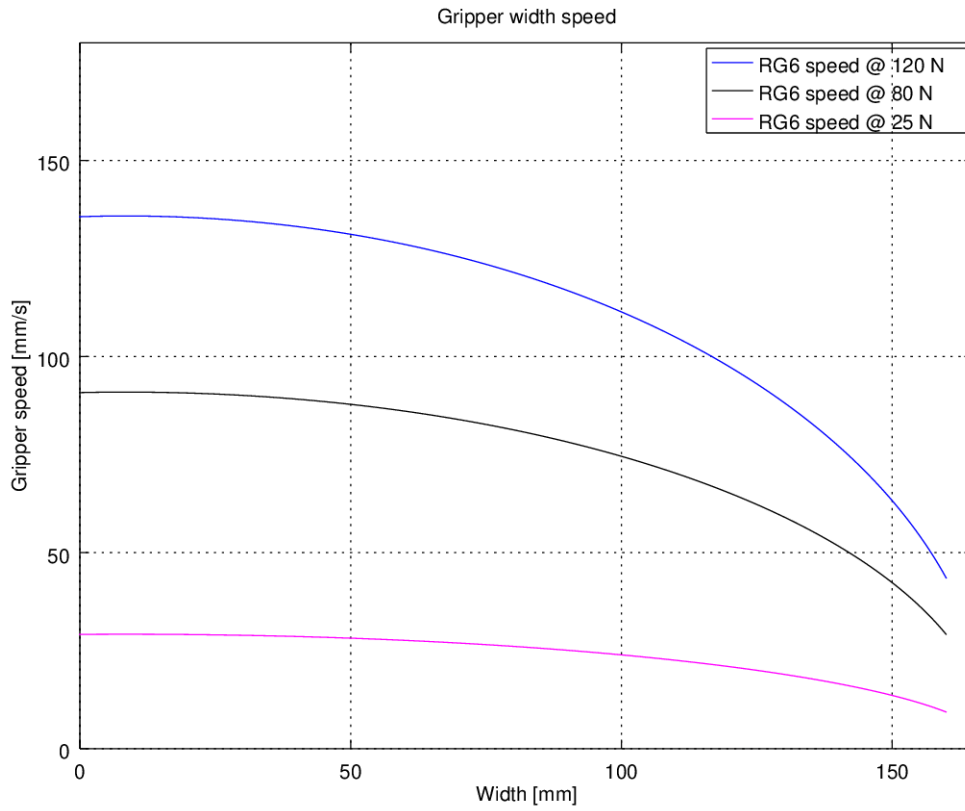

RG6 Work Range

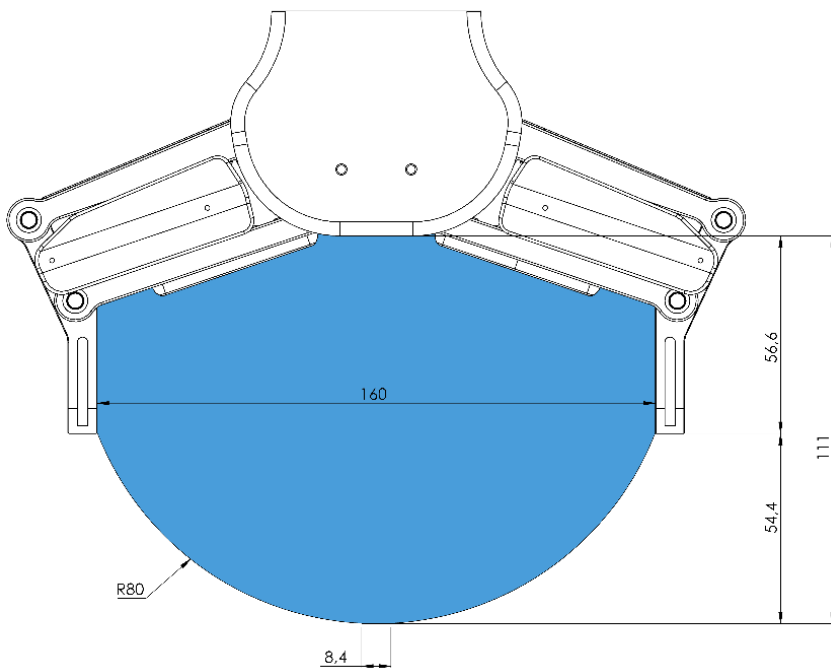

Gripping on long objects can unintentionally activate the Safety switches. The maximum workpiece height (calculated from the end of the fingertips) is dependent on the gripping width (w). For various width values the height (h) limit is given below:

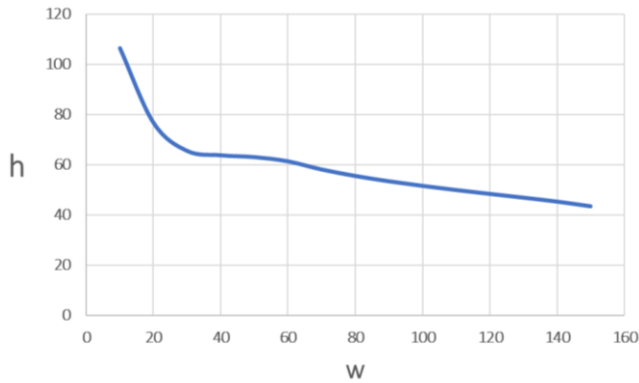

Fingertips

The standard fingertips can be used for many different workpieces. If custom fingertips are required, they can be made to fit the Gripper's fingers according to the dimensions (mm) shown below:

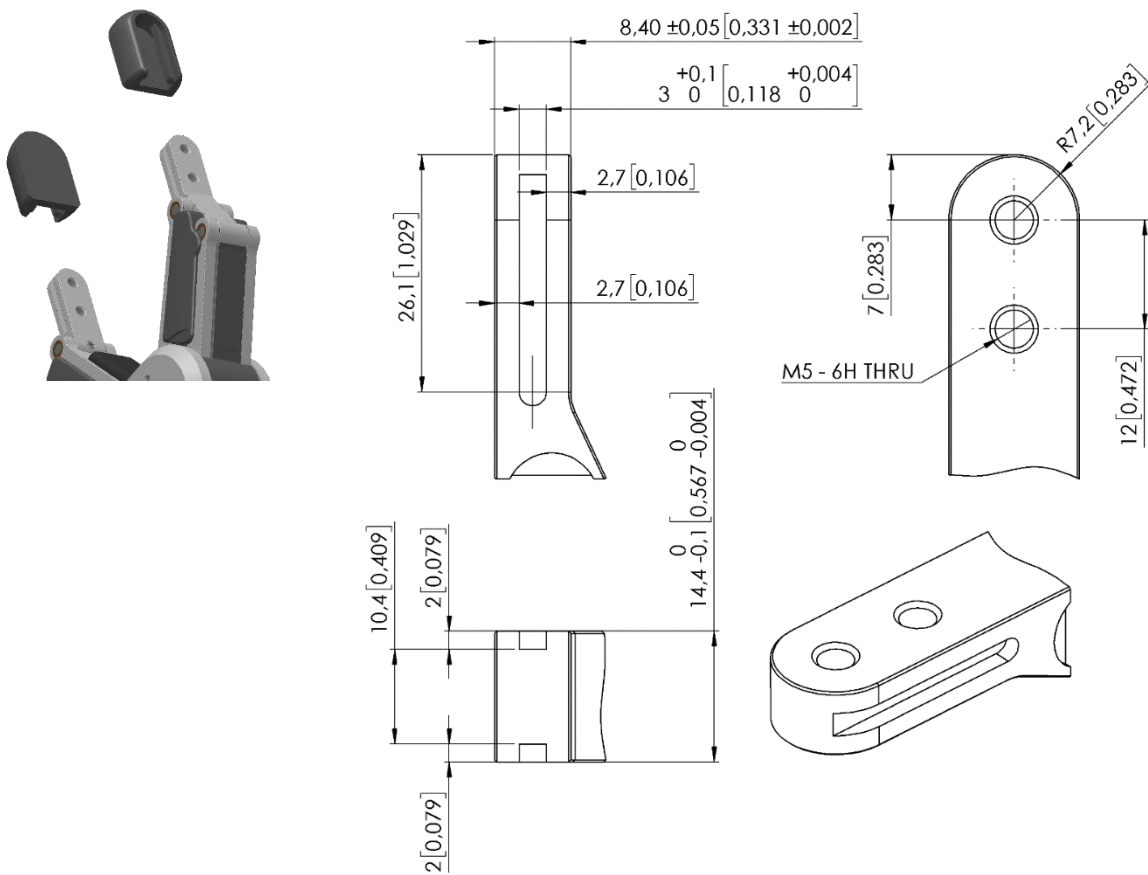

VG10

General Properties		Minimum	Typical	Maximum	Unit
Vacuum		5 % -0.05 1.5	- - -	80 % -0.810 24	[Vacuum] [Bar] [inHg]
Air flow		0	-	12	[L/min]
Arms adjustment		0	-	270	[°]
Arm holding torque		-	6	-	[Nm]
Payload	Rated	10 22			[kg] [lb]
	Maximum	15 33			[kg] [lb]
Vacuum cups		1	-	16	[pcs.]
Gripping time		-	0.35	-	[s]
Releasing time		-	0.20	-	[s]
Foot-inch-foot		-	1.40	-	[s]
Vacuum pump		Integrated, electric BLDC			
Arms		4, adjustable by hand			
Dust filters		Integrated 50µm, field replaceable			
IP Classification		IP54			
Dimensions (folded)		105 x 146 x 146 4.13 x 5.75 x 5.75		[mm] [inch]	
Dimensions (unfolded)		105 x 390 x 390 4.13 x 15.35 x 15.35		[mm] [inch]	
Weight		1.62 3.57		[kg] [lb]	

Operating Conditions	Minimum	Typical	Maximum	Unit
Power supply	20.4	24	28.8	[V]
Current consumption	50	600	1500	[mA]
Operating temperature	0	-	50	[°C]
	32	-	122	[°F]
Relative humidity (non-condensing)	0	-	95	[%]
Calculated MTBF (operating life)	30.000	-	-	[hours]

Positioning the VG10 arms and channels

The arms can be folded to the preferred position simply by pulling in the arms. The torque needed to overcome the friction in the rotatable joints of the arm is high (6 N/m) to ensure that the arms do not move when handling 15 kg payloads.

The VG10 suction cups are grouped into two independent channels.

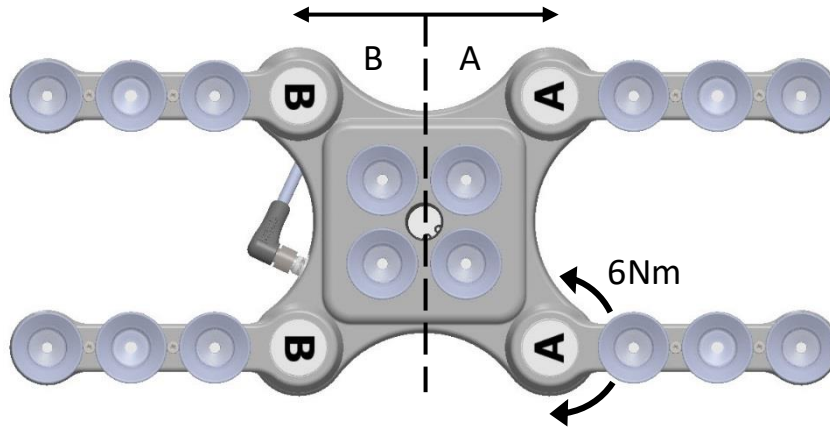

When the four arms are adjusted to preferred angles, it is recommended to add the accompanied arrow stickers. This allows for easy realignment and exchanging between different work items.





Payload

The lifting capacity of the VG grippers depends primarily on the following parameters:

- Vacuum cups
- Vacuum
- Air flow

Vacuum Cups

Choosing the right vacuum cups for your application is essential. The VG grippers come with common 15, 30 and 40 mm silicone vacuum cups (see table below) which are good for hard and flat surfaces, but not good for uneven surfaces and it might leave microscopic traces of silicone on the workpiece which can cause issues with some types of painting processes afterwards.



Image	External Diameter [mm]	Internal Diameter [mm]	Gripping Area [mm ²]
	15	6	110
	30	8	200
	40	12	450

For non-porous materials, the OnRobot suction cups are highly recommended. Some of the most common non-porous materials are listed below:

- Composites
- Glass
- High density cardboard
- High density paper
- Metals
- Plastic
- Porous materials with a sealed surface
- Varnished wood

In an ideal case, working with non-porous material workpieces where there are no air flow going through the workpiece, the table below shows the number of cups and the cup size needed depending on the payload (workpiece mass) and the vacuum used.

Number of Cups needed for non-porous materials depending on payload and vacuum:

Payload (kg)	 15mm				 30mm				 40mm			
	Vacuum (kPa)				Vacuum (kPa)				Vacuum (kPa)			
	20	40	60	75	20	40	60	75	20	40	60	75
1	7	4	3	2	4	2	2	1	2	1	1	1
2	14	7	5	4	8	4	3	2	4	2	2	1
3	-	11	7	6	12	6	4	3	5	3	2	2
4	-	14	9	8	15	8	5	4	7	4	3	2
5	-	-	12	9	-	10	7	5	9	5	3	3
6	-	-	14	11	-	12	8	6	10	5	4	3
7	-	-	16	13	-	13	9	7	12	6	4	4
8	-	-	-	15	-	15	10	8	14	7	5	4
9	-	-	-	-	-	-	12	9	15	8	5	4
10	-	-	-	-	-	-	-	13	-	9	6	5
11	-	-	-	-	-	-	-	14	-	9	6	5
12	-	-	-	-	-	-	-	15	-	10	7	6
13	-	-	-	-	-	-	-	16	-	11	8	6
14	-	-	-	-	-	-	-	-	-	12	8	7
15	-	-	-	-	-	-	-	-	-	13	9	7



NOTE:

To use more than 7 (15mm), 4 (30mm) or 3 (40mm) vacuum cups with the VGC10 a customized adaptor plate is needed.

The table above is created with the following formula that equalizes the lifting force with the payload considering 1.5g of acceleration.

$$\text{Amount}_{\text{Cups}} \cdot \text{Area}_{\text{Cup}} [\text{mm}^2] = 19600 \frac{\text{Payload} [\text{kg}]}{\text{Vacuum} [\text{kPa}]}$$

It is often a good idea to use more vacuum cups than needed, to accommodate for vibrations, leaks and other unexpected conditions. However, the more vacuum cups, the more air leakage (air flow) is expected and the more air is moved in a grip resulting in longer gripping times.

When using porous materials, the vacuum that can be achieved by using the OnRobot suction cups will depend on the material itself and will be between the range stated in the specifications. Some of the most common non-porous materials are listed below:

- Fabrics
- Foam
- Foam with open cells

Hardware Specification

- Low density cardboard
- Low density paper
- Perforated materials
- Untreated wood

See the table below with general recommendations, in case other suction cups are needed for specific materials.

Workpiece surface	Vacuum cup shape	Vacuum cup material
Hard and flat	Normal or dual lip	Silicone or NBR
Soft plastic or plastic bag	Special plastic bag type	Special plastic bag type
Hard but curved or uneven	Thin dual lip	Silicone or soft NBR
To be painted afterwards	Any type	NBR only
Varying heights	1.5 or more bevels	Any type



NOTE:

It is recommended to consult a vacuum cup specialist to find the optimal vacuum cup where the standard types are insufficient.

Fittings and Blind Screws.

It is possible to change suction cups simply by pulling them off the fittings. It might be a bit challenging to remove the 15 mm Diameter vacuum cups. As suggestion try to stretch the silicon to one of the sides and then pull it out.

Unused holes can be blinded using a blind screw, and each fitting can be changed to a different type to match the desired suction cup. The fittings and the blinding screws are mounted or dismounted by screwing (2Nm tightening torque) or unscrewing them with the provided 3 mm Allen key.

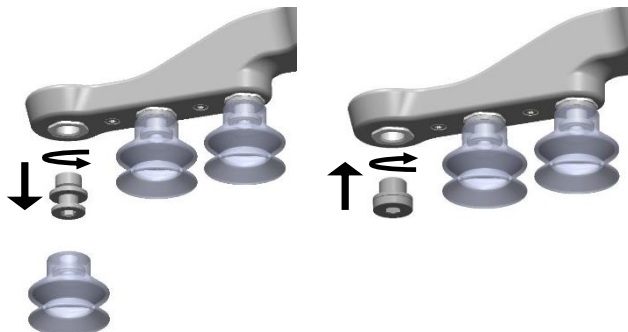

The thread size is the commonly used G1/8"; allowing for standard fittings, blinders and extenders to be fitted directly to the VG grippers.

Vacuum

Vacuum is defined as the percentage of absolute vacuum achieved relative to atmospheric pressure, i.e.:

% vacuum	Bar	kPa	inHg	Typically used for
0%	0.00rel. 1.01 abs.	0.00rel. 101.3 abs.	0.0rel. 29.9 abs.	No vacuum / No lifting capacity
20%	0.20rel. 0.81 abs.	20.3rel. 81.1 abs.	6.0rel. 23.9 abs.	Cardboard and thin plastics
40%	0.41rel. 0.61 abs.	40.5rel. 60.8 abs.	12.0rel. 18.0 abs.	Light workpieces and long suction cup life span
60%	0.61rel. 0.41 abs.	60.8rel. 40.5 abs.	18.0rel. 12.0 abs.	Heavy workpieces and strongly secured grips
80%	0.81rel. 0.20 abs.	81.1rel. 20.3 abs.	23.9rel. 6.0 abs.	Max. vacuum. Not recommended

The vacuum in kPa setting is the target vacuum. The pump will run at full speed until the target vacuum is achieved, and then run at a lower speed necessary to maintain the target vacuum.

The pressure in the atmosphere varies with weather, temperature and altitude. The VG grippers automatically compensate for altitudes up to 2km, where the pressure is about 80% of sea level.

Air flow

Air flow is the amount of air that must be pumped to maintain the target vacuum. A completely tight system will not have any air flow, whereas real life applications have some smaller air leakages from two different sources:

- Leaking vacuum cup lips
- Leaking workpieces

The smallest leak under a vacuum cup can be hard to find (see picture below).

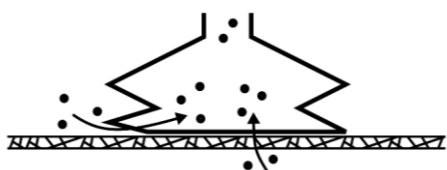

Leaking workpieces can be even harder to identify. Things that look completely tight might not be tight at all. A typical example is coarse cardboard boxes. The thin outer layer is often requiring a lot of air flow to create a pressure difference over it (see figure below).



Therefore, the users must be aware of the following:

- VG grippers are not suitable for most uncoated, coarse cardboard boxes.

- Extra attention must be paid to leakages, e.g. vacuum cup shape and surface roughness

The air flow capability of a VG grippers is shown in the graph below:

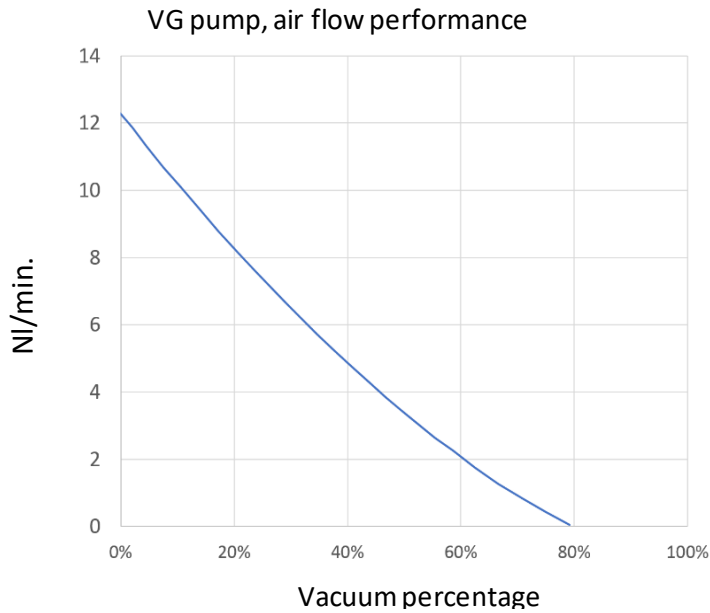

NOTE:

The easiest way to check if a cardboard box is sufficiently tight is simply to test it using the VG grippers.

A high vacuum percentage setting does not give a higher lifting capacity on corrugated cardboard. In fact, a lower setting is recommended, e.g. 20%.

A low vacuum setting results in less air flow and less friction below the vacuum cups. This means VG gripper filters and vacuum cups will last longer.

VGC10

General Properties		Minimum	Typical	Maximum	Unit
Vacuum		5 % -0.05 1.5	- - -	80 % -0.810 24	[Vacuum] [Bar] [inHg]
Air flow		0	-	12	[L/min]
Payload	With default attachments	- -	- -	6 * 13.2 *	[kg] [lb]
	With customized attachments	- -	10 22	15 33.1	[kg] [lb]
Vacuum cups		1	-	7	[pcs.]
Gripping time		-	0.35	-	[s]
Releasing time		-	0.20	-	[s]
Vacuum pump		Integrated, electric BLDC			
Dust filters		Integrated 50µm, field replaceable			
IP Classification		IP54			
Dimensions		101 x 100 x 100 3.97 x 3.94 x 3.94		[mm] [inch]	
Weight		0.814 1.79		[kg] [lb]	

* By using three 40mm cups. More info in a table on [page 76](#).

Operating Conditions	Minimum	Typical	Maximum	Unit
Power supply	20.4	24	28.8	[V]
Current consumption	50	600	1500	[mA]
Operating temperature	0	-	50	[°C]
	32	-	122	[°F]
Relative humidity (non-condensing)	0	-	95	[%]
Calculated MTBF (operating life)	30.000	-	-	[hours]

2 channels

The VGC10 has 4 holes to use fittings with vacuum cups or blinding screws as needed. It also has lines which show the holes that are communicated together. This is useful when using channels A and B independently for vacuum.

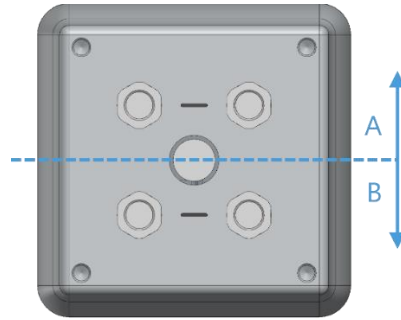
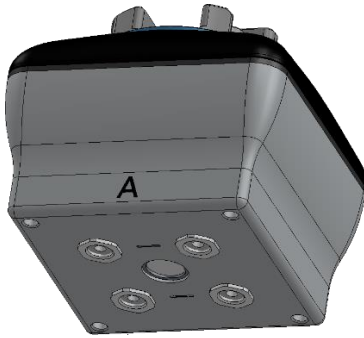

Adaptor Plate

The VGC10 comes with an Adaptor Plate which provides extra flexibility to locate the vacuum cups in different configurations.

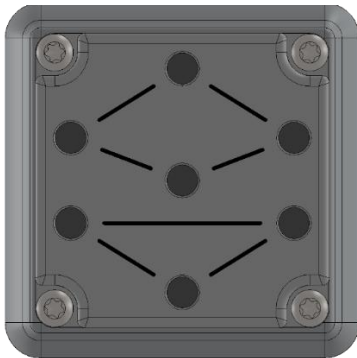

The Adaptor Plate has 7 holes to use fittings with vacuum cups or blinding screws as needed. It also has lines which show the holes that are communicated together. This is useful when using channel A and B independently for vacuum.

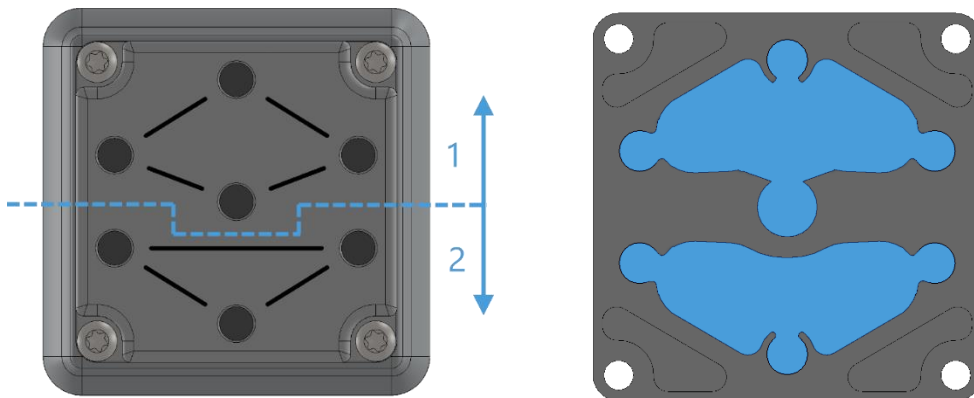

The Adaptor Plate can be placed in different positions by rotating it 90°. Having as reference the letters A and B written on the gripper housing, the Adaptor Plate can be placed to separate both channels or to communicate them. If the Adaptor Plate is placed as in picture below on the left, both channels will be separated, and they can be used independently or combined. If the Adaptor Plate is placed as in picture below on the right, both channels will be communicated and a higher air flow can be achieved, although both channels will have to be used combined.

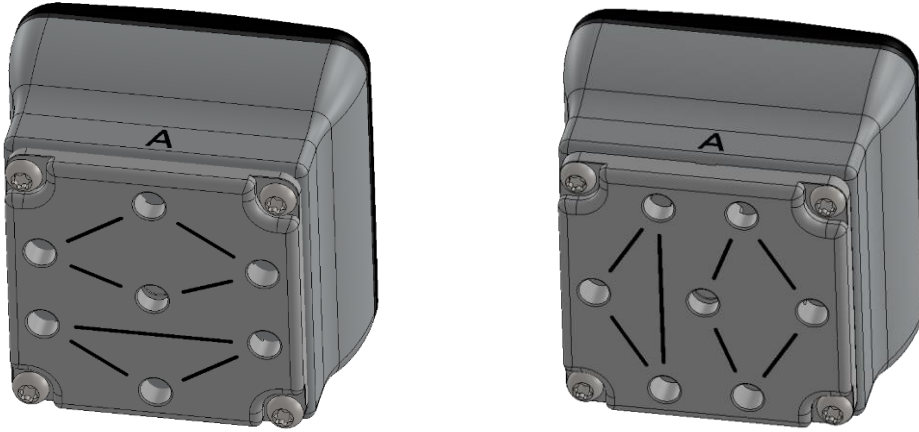

To mount the Adaptor Plate simply remove the 4 fittings or blinding screws from the gripper, place the Adaptor Plate by choosing the right angle according to the desired configuration, and tighten the 4 screws with 4 Nm tighten torque.

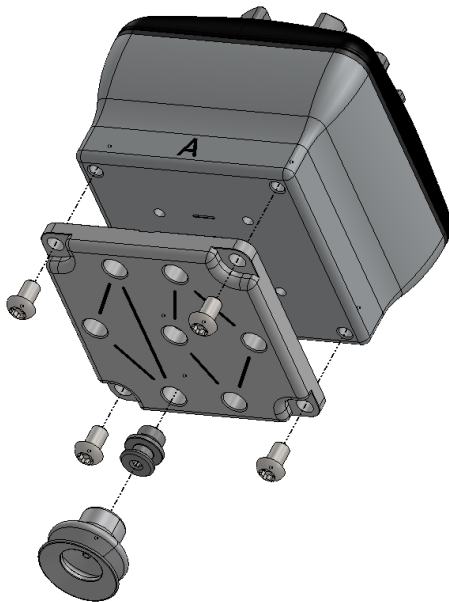

NOTE:

Please, note that the O-Ring in the Adaptor Plate is not glued therefore it can be pulled out. If that happens simply put it back in place and the gripper will work as before.

Extension Pipe

The Extension Pipe provides an extra length of 50 mm to reach narrow spaces.



NOTE:

Remember to use the Adaptor Plate rotated to achieve a higher air flow when using both channels together.

The Extension Pipe can be mounted in any of the holes by simply screwing it in and adding a fitting on top as shown in the image below.



Below different mounting configurations with the provided attachments are shown.



Customized Adaptor Plates and Push-in Fittings

The design of the VGC10 is meant to facilitate the users to make their own adaptor plates to create different kinds of configurations. The dimensions needed to create a customized adaptor plate are shown in the image below.

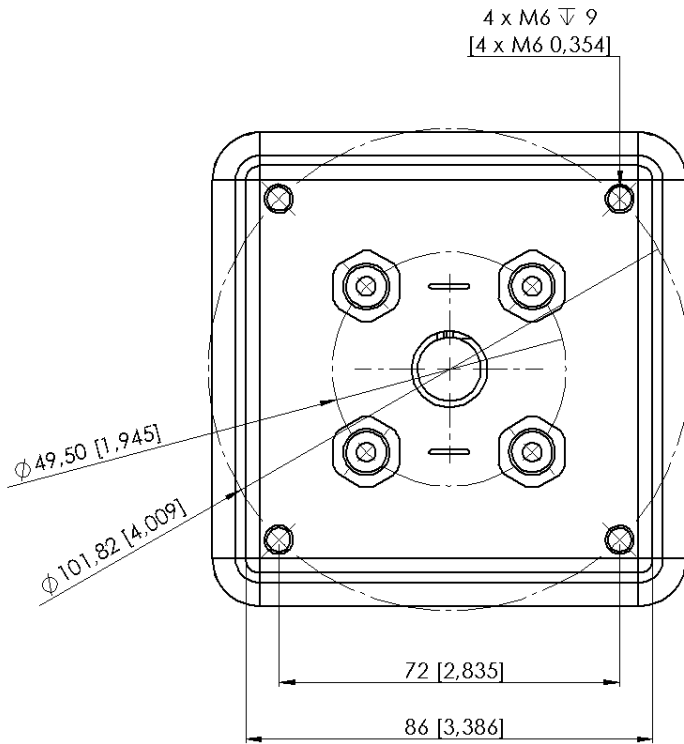

The Push-in Fittings are used to attach 4 mm vacuum tubes to create customized configuration that required remote vacuum. In most cases, this size is enough for generating the needed vacuum from the pump in the gripper.



The commercial name of the Push-in Fittings is Fitting QSM-G1/8-4-I-R in case some more units need to be purchased.

An example of a customized configuration with a homemade adaptor plate and remote vacuum is shown below.

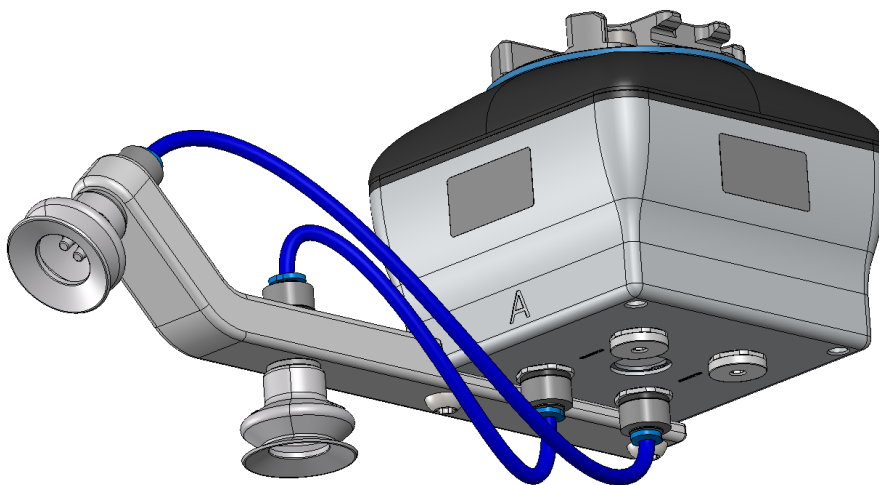

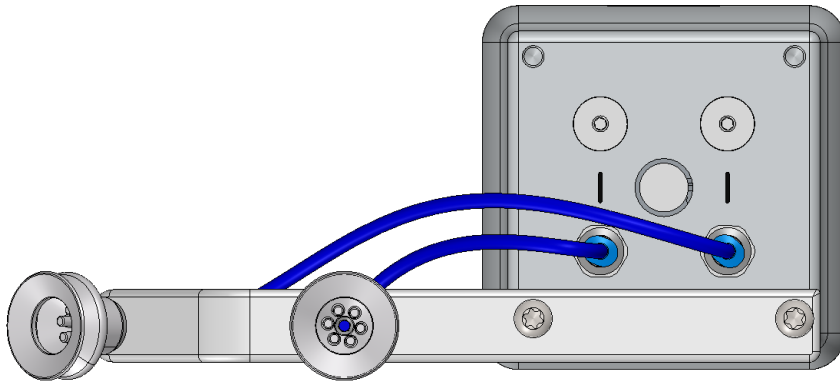

The image below shows how the push-in fittings and the normal fittings are communicated.

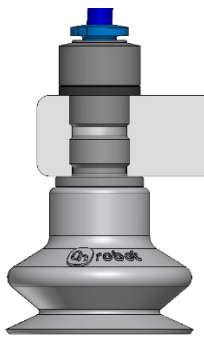

Payload

The lifting capacity of the VG grippers depends primarily on the following parameters:

- Vacuum cups
- Vacuum
- Air flow

Vacuum Cups

Choosing the right vacuum cups for your application is essential. The VG grippers come with common 15, 30 and 40 mm silicone vacuum cups (see table below) which are good for hard and flat surfaces, but not good for uneven surfaces and it might leave microscopic traces of silicone on the workpiece which can cause issues with some types of painting processes afterwards.



Image	External Diameter [mm]	Internal Diameter [mm]	Gripping Area [mm ²]
	15	6	110
	30	8	200
	40	12	450

For non-porous materials, the OnRobot suction cups are highly recommended. Some of the most common non-porous materials are listed below:

- Composites
- Glass
- High density cardboard
- High density paper
- Metals
- Plastic
- Porous materials with a sealed surface
- Varnished wood

In an ideal case, working with non-porous material workpieces where there are no air flow going through the workpiece, the table below shows the number of cups and the cup size needed depending on the payload (workpiece mass) and the vacuum used.

Number of Cups needed for non-porous materials depending on payload and vacuum:

Payload (kg)	 15mm				 30mm				 40mm			
	Vacuum (kPa)				Vacuum (kPa)				Vacuum (kPa)			
	20	40	60	75	20	40	60	75	20	40	60	75
1	7	4	3	2	4	2	2	1	2	1	1	1
2	14	7	5	4	8	4	3	2	4	2	2	1
3	-	11	7	6	12	6	4	3	5	3	2	2
4	-	14	9	8	15	8	5	4	7	4	3	2
5	-	-	12	9	-	10	7	5	9	5	3	3
6	-	-	14	11	-	12	8	6	10	5	4	3
7	-	-	16	13	-	13	9	7	12	6	4	4
8	-	-	-	15	-	15	10	8	14	7	5	4
9	-	-	-	-	-	-	12	9	15	8	5	4
10	-	-	-	-	-	-	13	10	-	9	6	5
11	-	-	-	-	-	-	14	11	-	9	6	5
12	-	-	-	-	-	-	15	12	-	10	7	6
13	-	-	-	-	-	-	16	13	-	11	8	6
14	-	-	-	-	-	-	-	14	-	12	8	7
15	-	-	-	-	-	-	-	15	-	13	9	7

NOTE:



To use more than 7 (15mm), 4 (30mm) or 3 (40mm) vacuum cups with the VGC10 a customized adaptor plate is needed.

The table above is created with the following formula that equalizes the lifting force with the payload considering 1.5g of acceleration.

$$\text{Amount}_{\text{Cups}} \cdot \text{Area}_{\text{Cup}} [\text{mm}^2] = 19600 \frac{\text{Payload} [\text{kg}]}{\text{Vacuum} [\text{kPa}]}$$

It is often a good idea to use more vacuum cups than needed, to accommodate for vibrations, leaks and other unexpected conditions. However, the more vacuum cups, the more air leakage (air flow) is expected and the more air is moved in a grip resulting in longer gripping times.

When using porous materials, the vacuum that can be achieved by using the OnRobot suction cups will depend on the material itself and will be between the range stated in the specifications. Some of the most common non-porous materials are listed below:

- Fabrics
- Foam
- Foam with open cells
- Low density cardboard
- Low density paper
- Perforated materials
- Untreated wood

See the table below with general recommendations, in case other suction cups are needed for specific materials.

Workpiece surface	Vacuum cup shape	Vacuum cup material
Hard and flat	Normal or dual lip	Silicone or NBR
Soft plastic or plastic bag	Special plastic bag type	Special plastic bag type
Hard but curved or uneven	Thin dual lip	Silicone or soft NBR
To be painted afterwards	Any type	NBR only
Varying heights	1.5 or more bevels	Any type



NOTE:

It is recommended to consult a vacuum cup specialist to find the optimal vacuum cup where the standard types are insufficient.

Fittings and Blind Screws.

It is possible to change suction cups simply by pulling them off the fittings. It might be a bit challenging to remove the 15 mm Diameter vacuum cups. As suggestion try to stretch the silicon to one of the sides and then pull it out.

Unused holes can be blinded using a blind screw, and each fitting can be changed to a different type to match the desired suction cup. The fittings and the blinding screws are mounted or dismounted by screwing (2Nm tightening torque) or unscrewing them with the provided 3 mm Allen key.

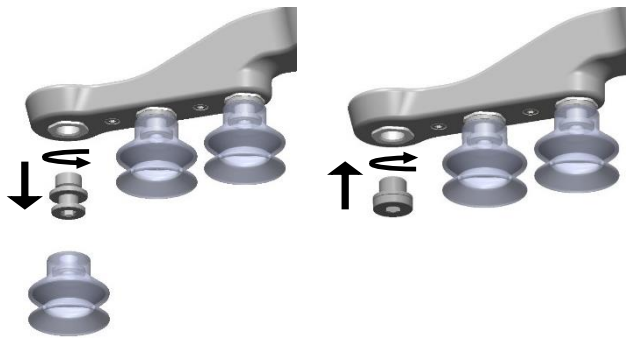

The thread size is the commonly used G1/8"; allowing for standard fittings, blinders and extenders to be fitted directly to the VG grippers.

Vacuum

Vacuum is defined as the percentage of absolute vacuum achieved relative to atmospheric pressure, i.e.:

% vacuum	Bar	kPa	inHg	Typically used for
0%	0.00rel. 1.01 abs.	0.00rel. 101.3 abs.	0.0rel. 29.9 abs.	No vacuum / No lifting capacity
20%	0.20rel. 0.81 abs.	20.3rel. 81.1 abs.	6.0rel. 23.9 abs.	Cardboard and thin plastics
40%	0.41rel. 0.61 abs.	40.5rel. 60.8 abs.	12.0rel. 18.0 abs.	Light workpieces and long suction cup life span
60%	0.61rel. 0.41 abs.	60.8rel. 40.5 abs.	18.0rel. 12.0 abs.	Heavy workpieces and strongly secured grips
80%	0.81rel. 0.20 abs.	81.1rel. 20.3 abs.	23.9rel. 6.0 abs.	Max. vacuum. Not recommended

The vacuum in kPa setting is the target vacuum. The pump will run at full speed until the target vacuum is achieved, and then run at a lower speed necessary to maintain the target vacuum.

The pressure in the atmosphere varies with weather, temperature and altitude. The VG grippers automatically compensate for altitudes up to 2km, where the pressure is about 80% of sea level.

Air flow

Air flow is the amount of air that must be pumped to maintain the target vacuum. A completely tight system will not have any air flow, whereas real life applications have some smaller air leakages from two different sources:

- Leaking vacuum cup lips
- Leaking workpieces

The smallest leak under a vacuum cup can be hard to find (see picture below).

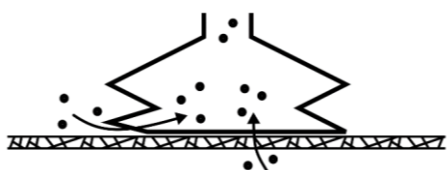

Leaking workpieces can be even harder to identify. Things that look completely tight might not be tight at all. A typical example is coarse cardboard boxes. The thin outer layer is often requiring a lot of air flow to create a pressure difference over it (see figure below).

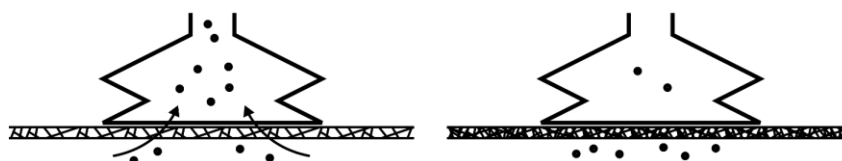

Therefore, the users must be aware of the following:

- VG grippers are not suitable for most uncoated, coarse cardboard boxes.

- Extra attention must be paid to leakages, e.g. vacuum cup shape and surface roughness

The air flow capability of a VG grippers is shown in the graph below:

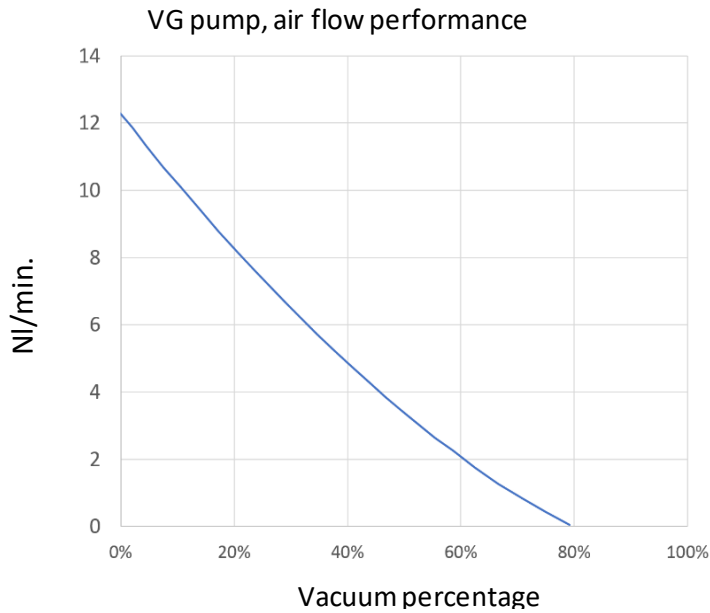

NOTE:

The easiest way to check if a cardboard box is sufficiently tight is simply to test it using the VG grippers.

A high vacuum percentage setting does not give a higher lifting capacity on corrugated cardboard. In fact, a lower setting is recommended, e.g. 20%.





A low vacuum setting results in less air flow and less friction below the vacuum cups. This means VG gripper filters and vacuum cups will last longer.

7.2 Mechanical Drawings

7.2.1 Adapter plate(s)

No adapter plates are required.

7.2.2 Mountings

 Quick Changer - Robot side	95
 Quick Changer for I/O - Robot side ...	96
 Dual Quick Changer	97
 HEX-E/H QC.....	98

Quick Changer -
Robot side

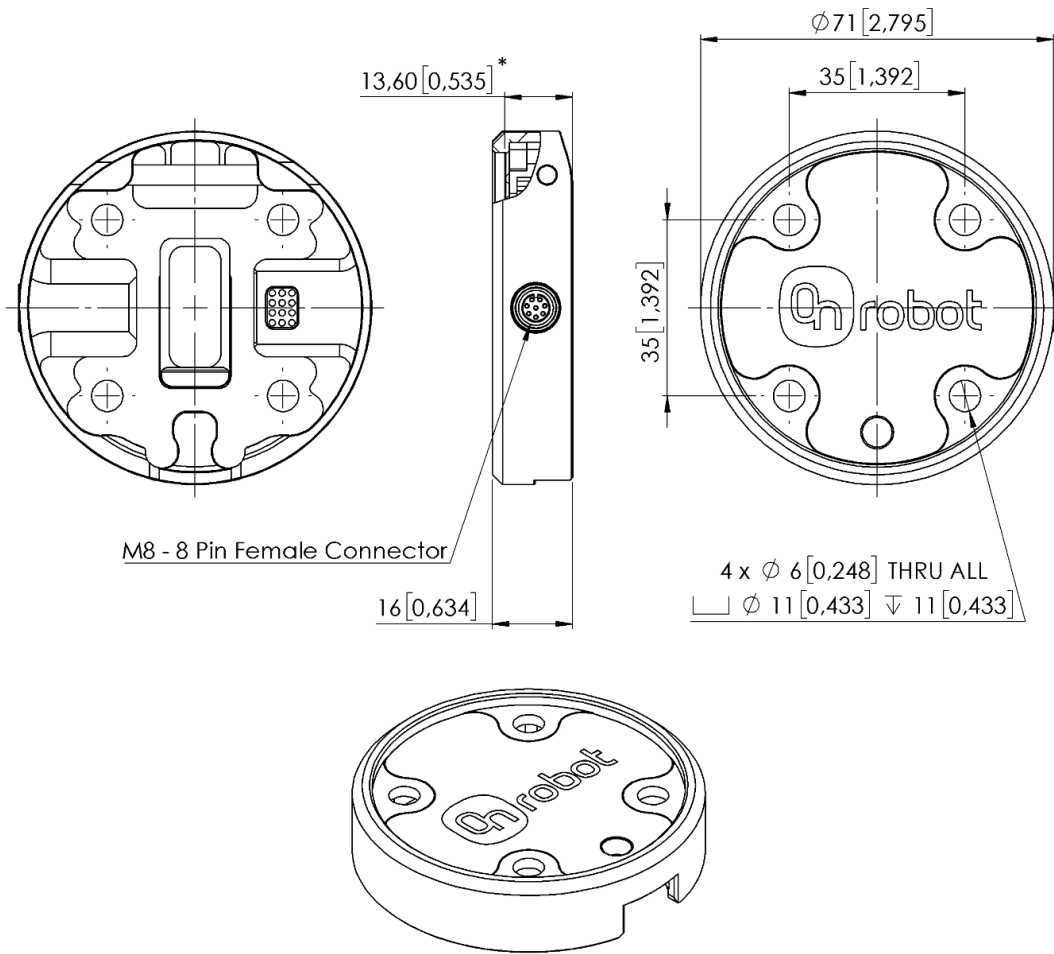

* Distance from Robot flange interface to OnRobot tool.

All dimensions are in mm and [inches].

Dual Quick Changer

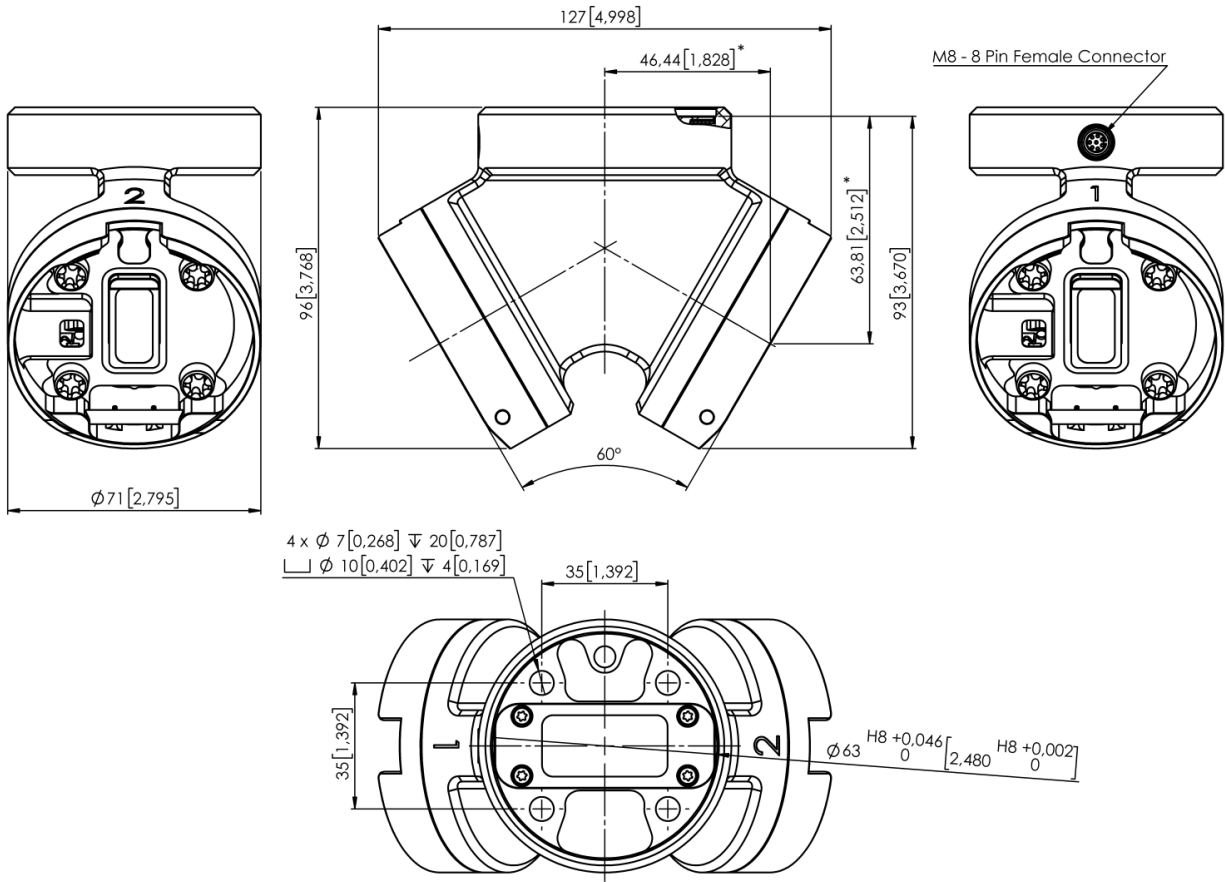

* Distance from Robot flange interface to OnRobot tool

All dimensions are in mm and [inches].



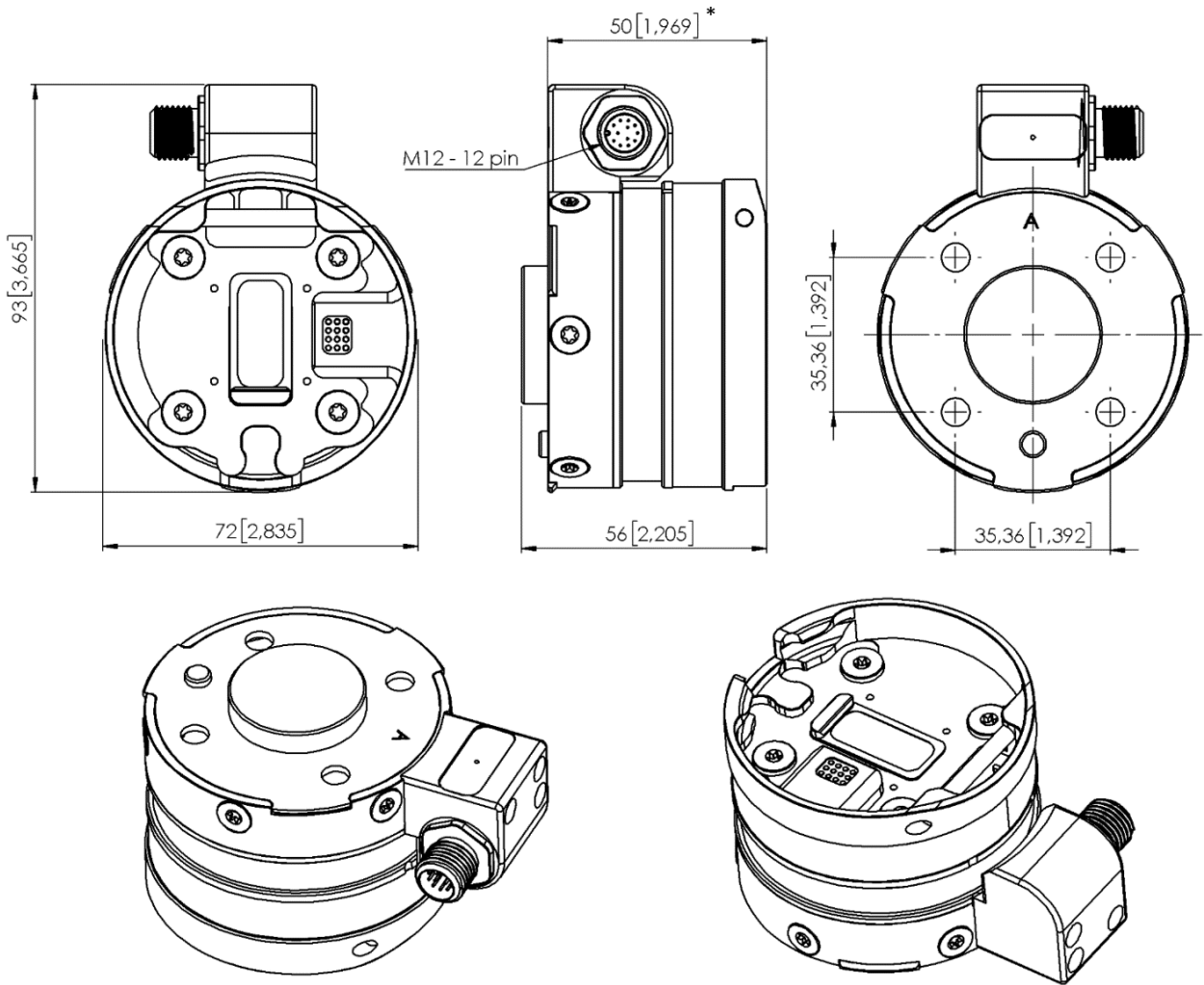



HEX-E/H QC



* Distance from Robot flange interface to OnRobot tool

All dimensions are in mm and [inches].

7.2.3 Tools

	Gecko.....	99
	RG2-FT	100
	RG2	101
	RG6	102
	VG10	103
	VGC10	105
	Quick Changer - Tool side.....	107

Gecko

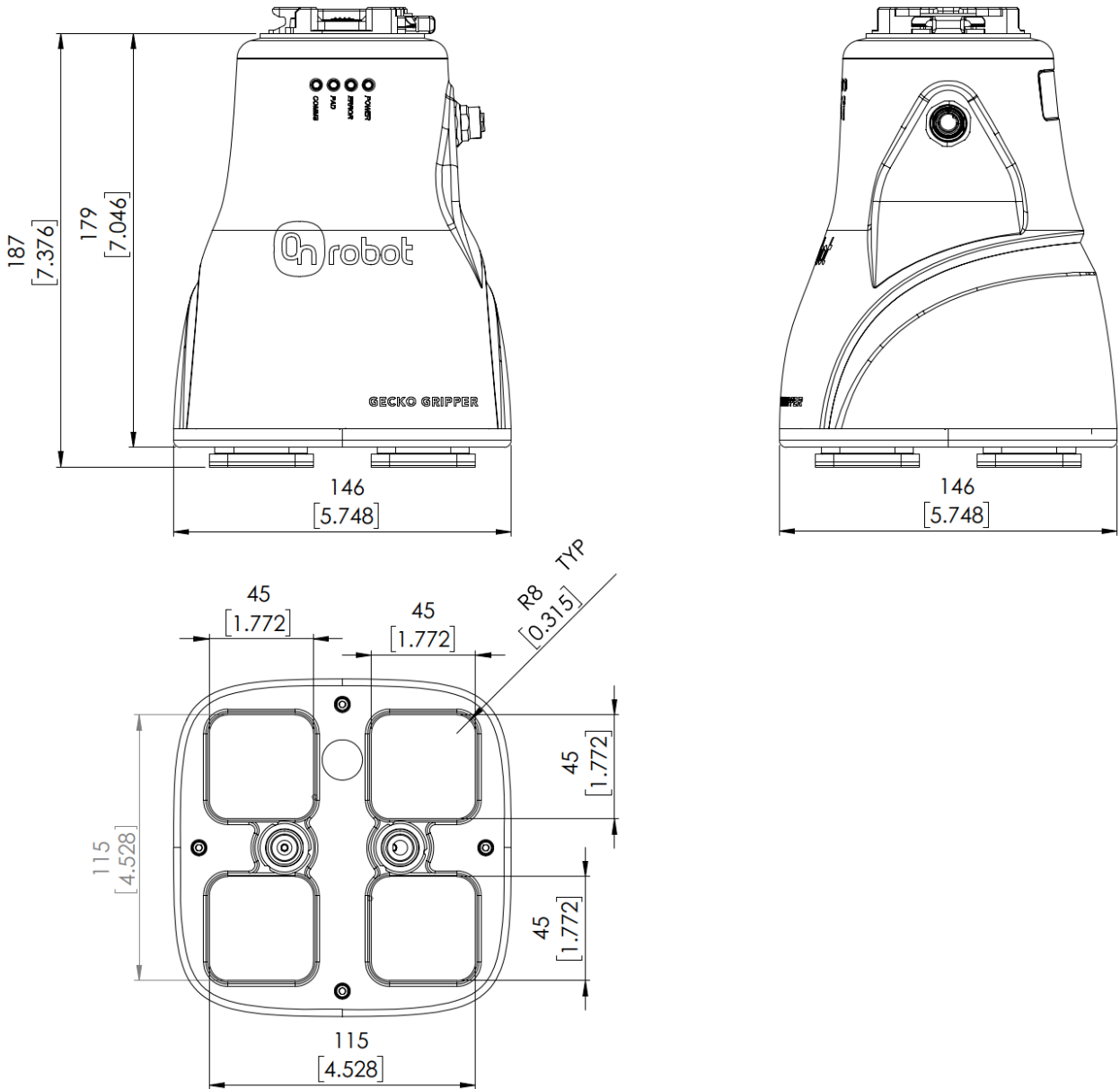

All dimensions are in mm and [inches].

RG2-FT

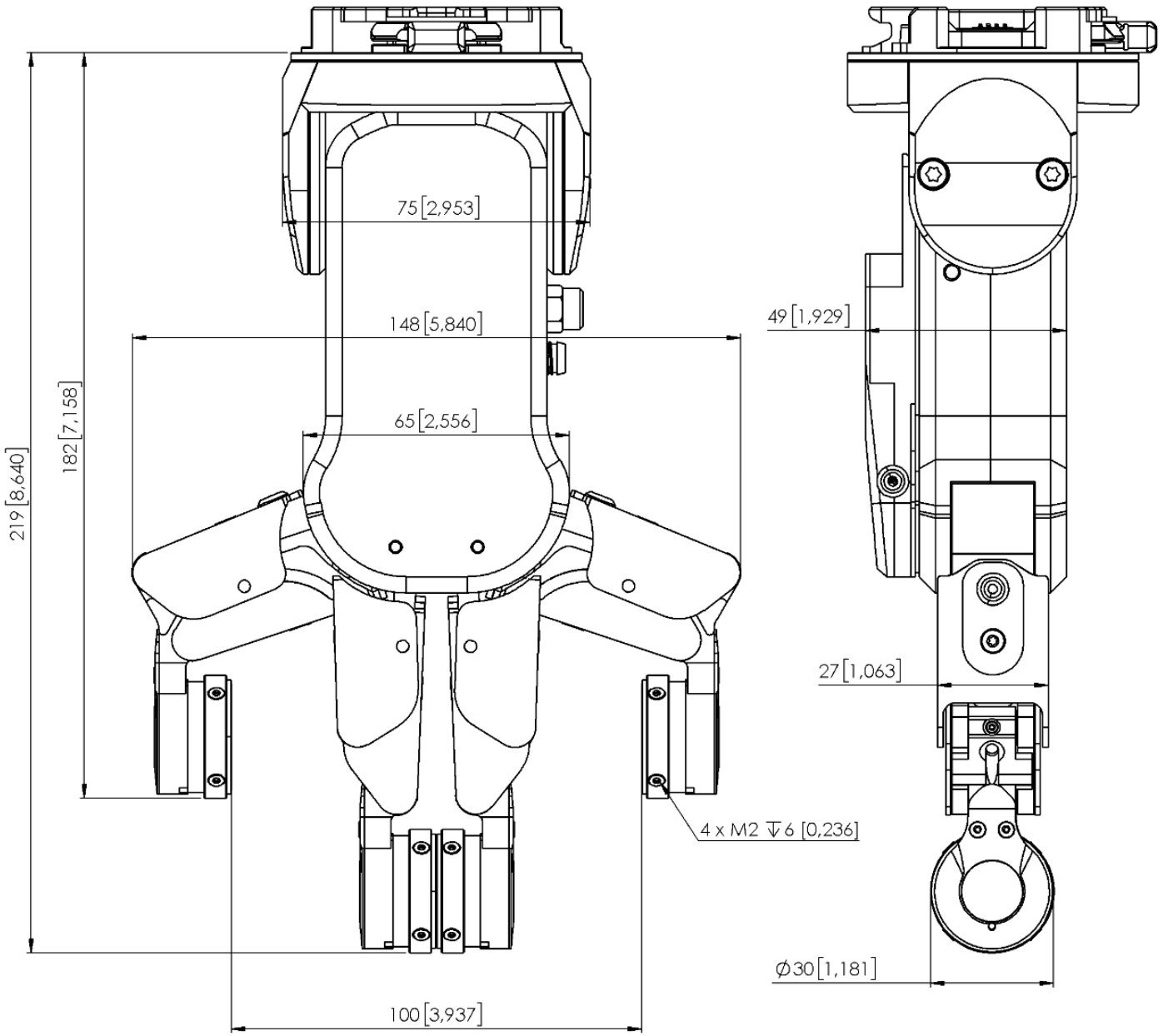

All dimensions are in mm and [inches].

RG2

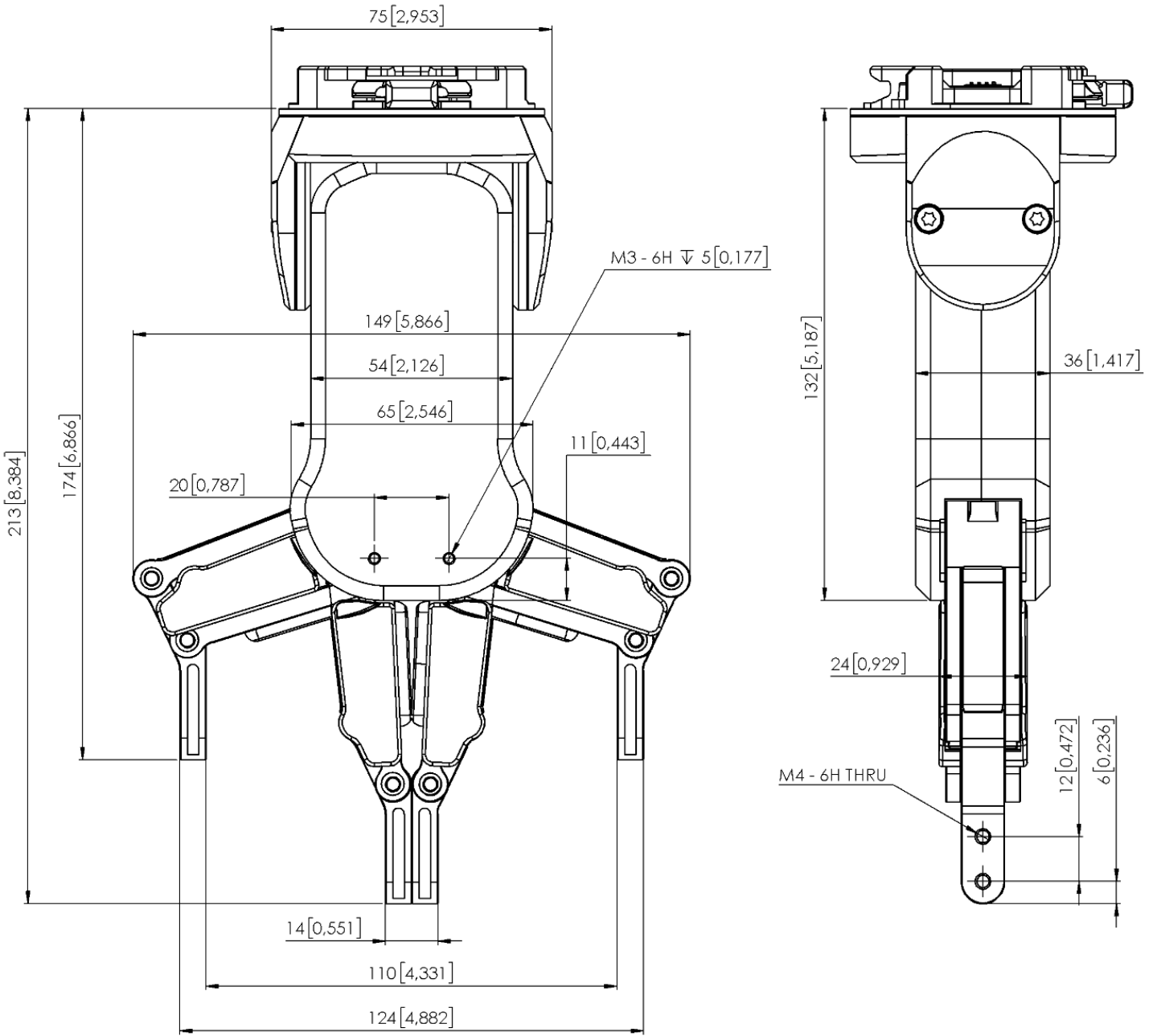

All dimensions are in mm and [inches].

RG6

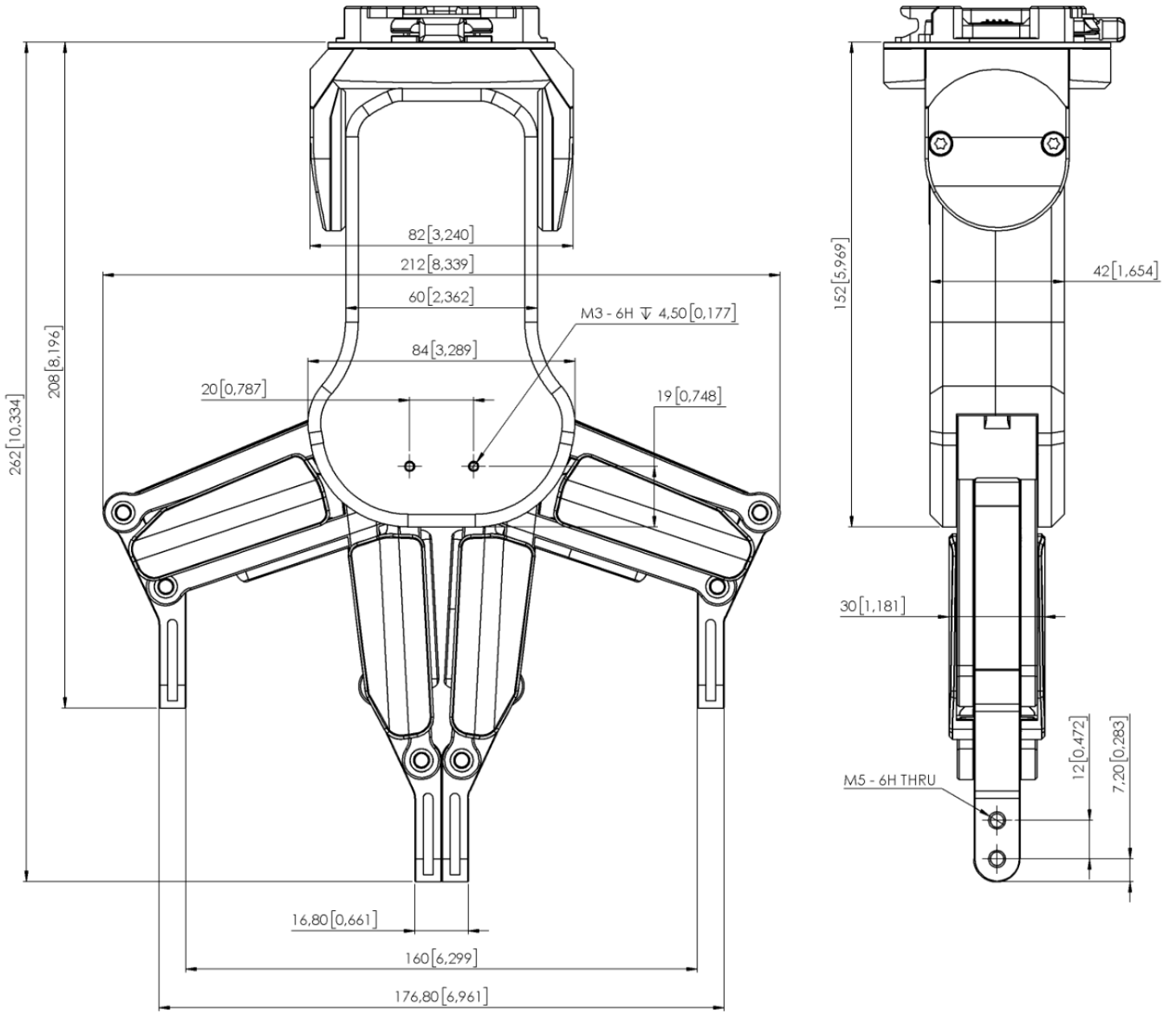

All dimensions are in mm and [inches].

VG10

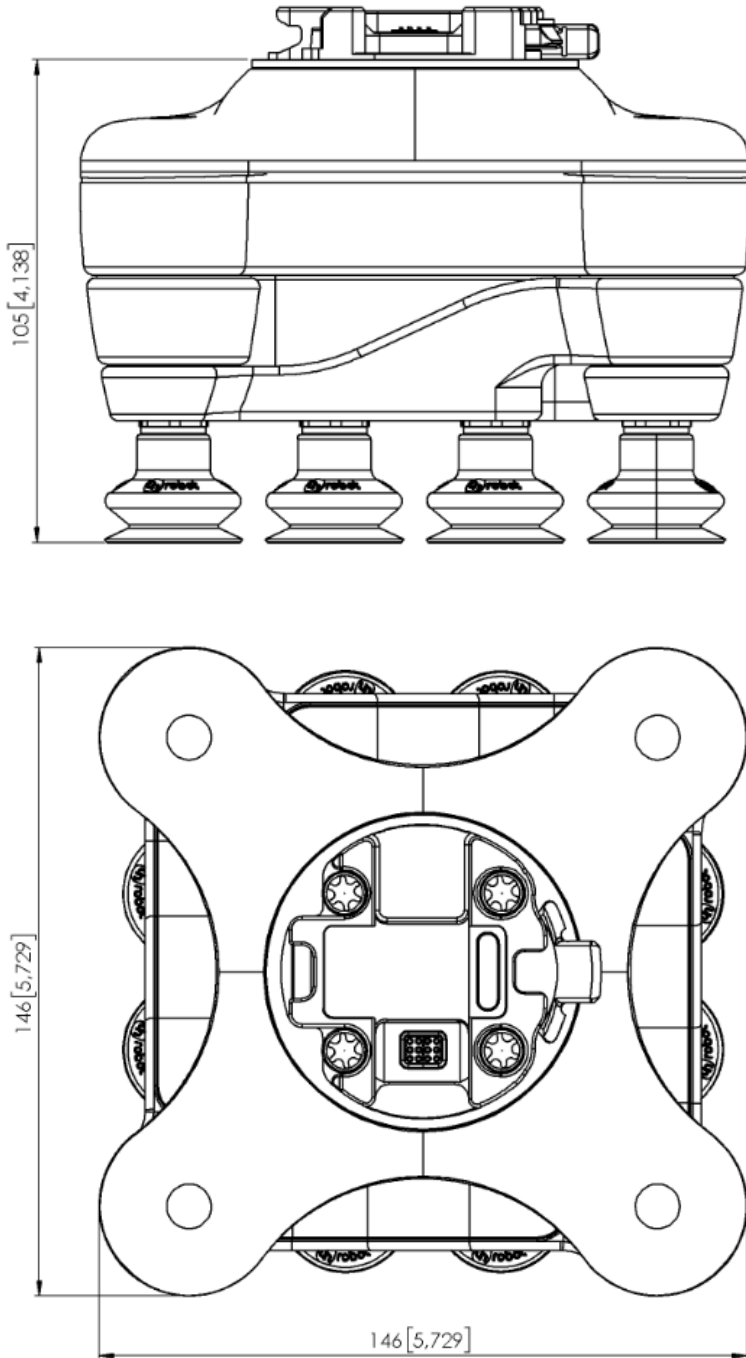

All dimensions are in mm and [inches].

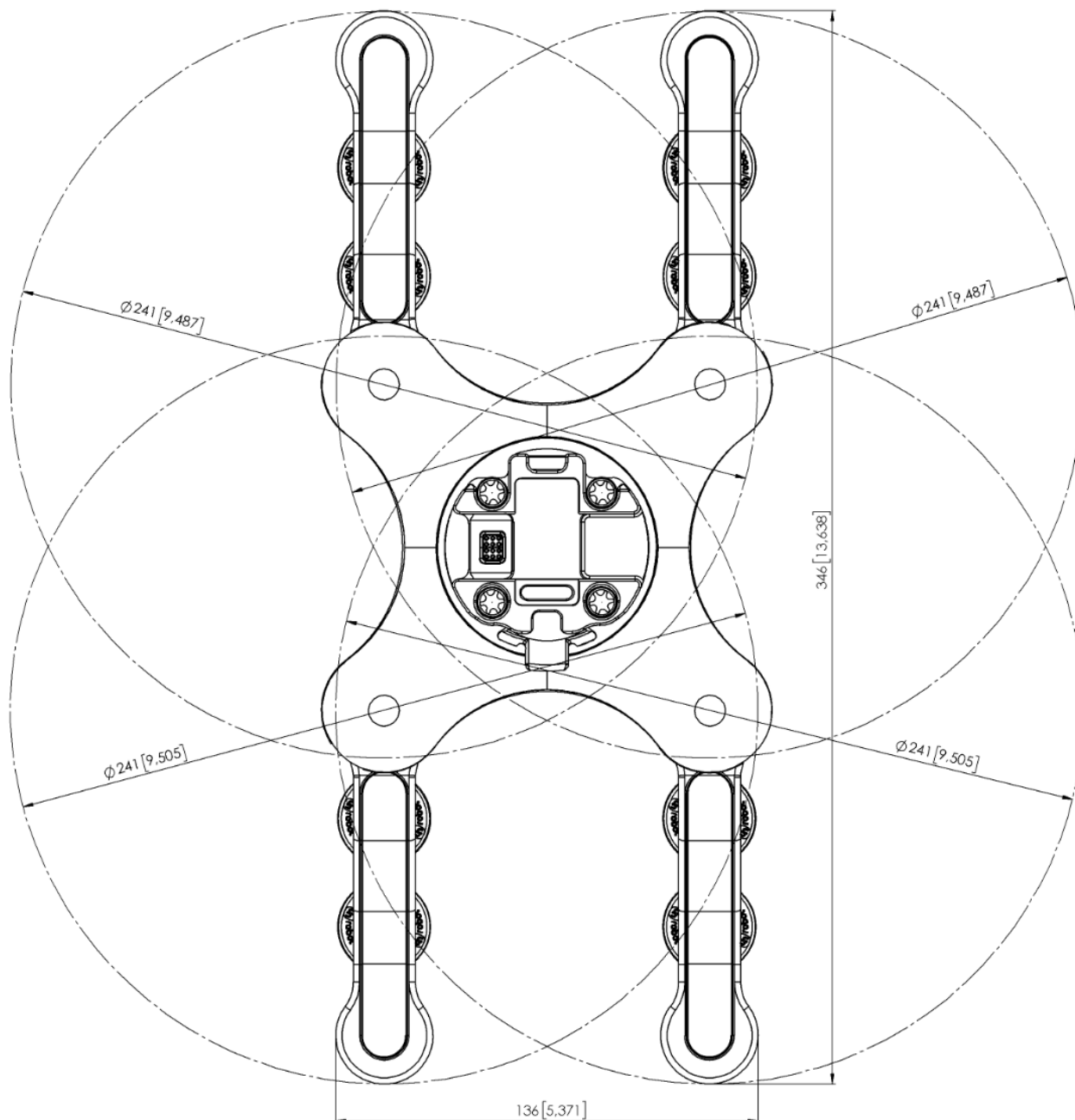

All dimensions are in mm and [inches].

VGC10

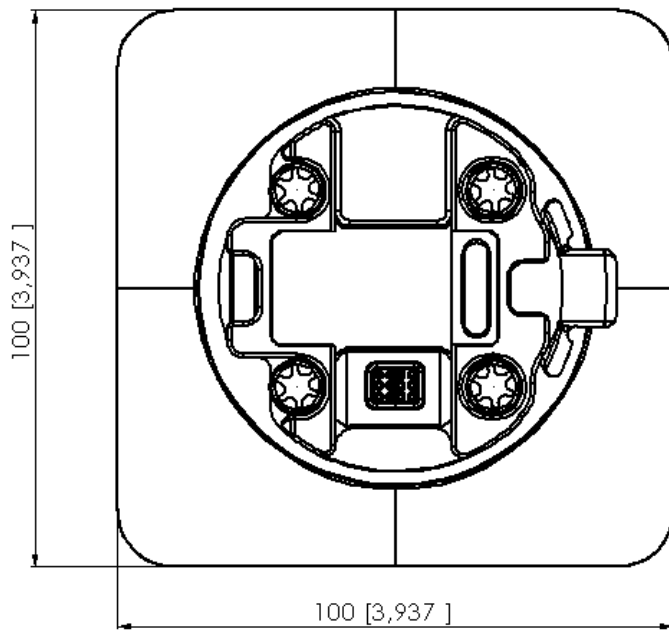
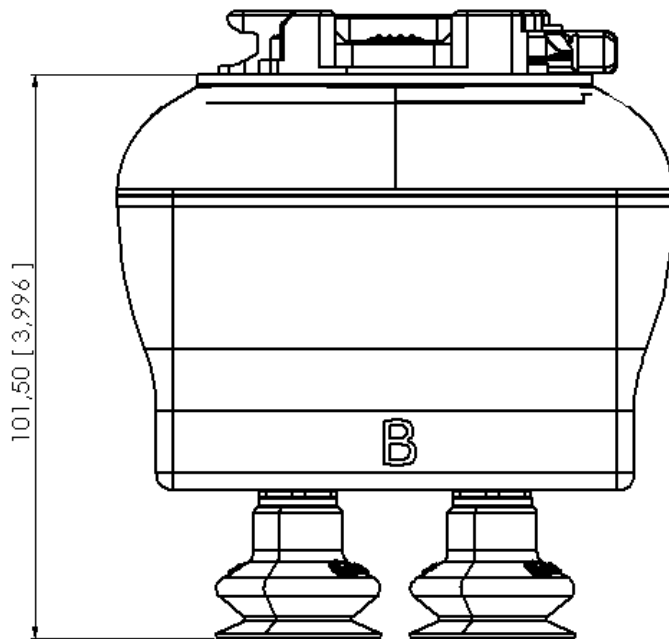

All dimensions are in mm and [inches].

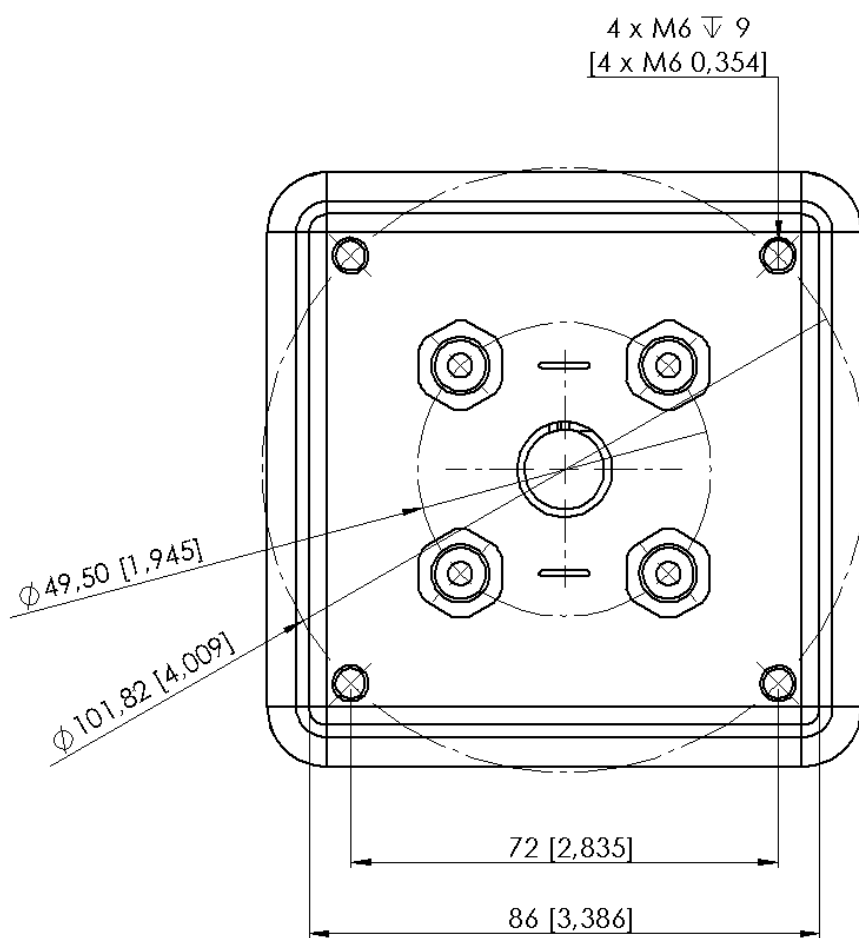

All dimensions are in mm and [inches].

Quick Changer -
Tool side

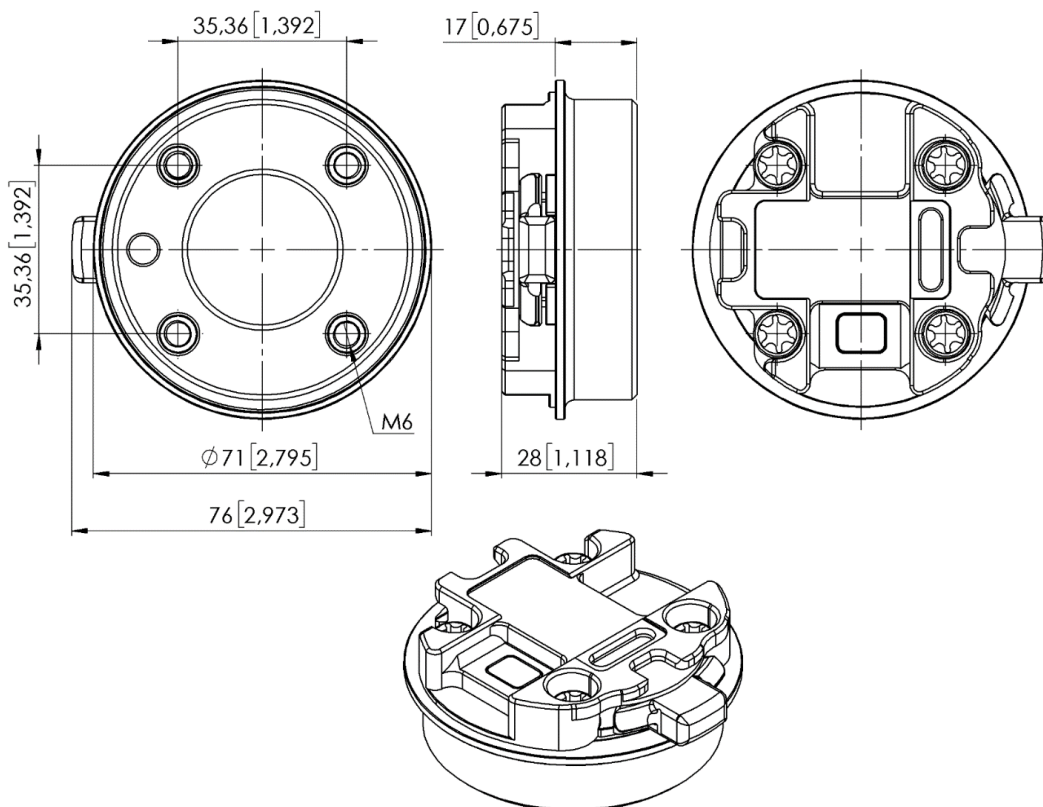

All dimensions are in mm and [inches].

7.3 Center of Gravity

COG, TCP, and weight parameters of the single devices (without any mounting/adapter):

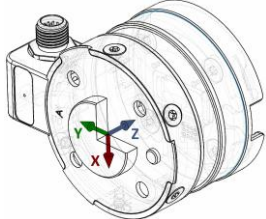
HEX-E/H QC			
Coordinate system	TCP [mm]	Center of Gravity [mm]	Weight
	X=0 Y=0 Z=50	cX=0 cY=5 cZ=20	0.35 kg 0.77 lb

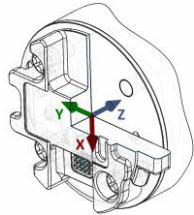
Gecko			
Coordinate system	TCP [mm]	Center of Gravity [mm]	Weight
	X=0 Y=0 Z=187	cX=0 cY=0 cZ=113	2.83 kg 6.10 lb

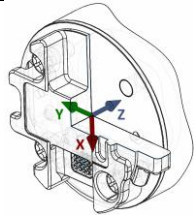
RG2-FT			
Coordinate system	TCP [mm]	Center of Gravity [mm]	Weight
	X=0 Y=0 Z=205	cX=0 cY=0 cZ=65	0.98 kg 2.16 lb

* Mounted at 0°

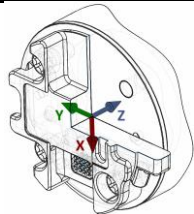
RG2			
Coordinate system	TCP [mm]	Center of Gravity [mm]	Weight
	X=0 Y=0 Z=200	cX=0 cY=0 cZ=64	0.78 kg 1.72 lb

* Mounted at 0°

RG6

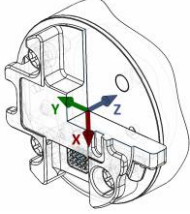
Coordinate system	TCP [mm]	Center of Gravity [mm]	Weight
	X=0 Y=0 Z=250	cX=0 cY=0 cZ=90	1.25 kg 2.76 lb

* Mounted at 0°

VG10

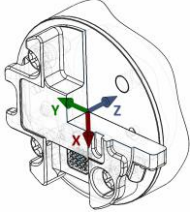
Coordinate system	TCP [mm]	Center of Gravity [mm]	Weight
	X=0 Y=0 Z=105	cX=15 cY=0 cZ=54	1.62 kg 3.57 lb

* With arms folded back

VGC10

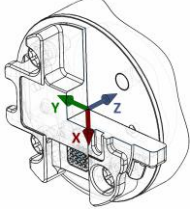
Coordinate system	TCP [mm]	Center of Gravity [mm]	Weight
	X=0 Y=0 Z=7	cX=-1 cY=-1 cZ=37	0.814 kg 1.79 lb

* With no attachments

8 Maintenance



WARNING:

An overall inspection of the OnRobot's End of Arm Tooling must be performed regularly and at least once every 6 months. This inspection must include but is not limited to check for defective material and clean gripping surfaces.

Use original spare parts, and original service instructions for the OnRobot's End of Arm Tooling and the robot. Failure to comply with this precaution can cause unexpected risks, resulting in severe injury.

If you have questions regarding spare parts and repair, please visit our website www.onrobot.com to contact us.

- Gecko.....110**
- RG2/6.....112**
- RG2-FT112**
- VG10 / VGC10.....112**

Gecko

Gecko Gripper pads are made from a precision cast silicone or polyurethane film with a gecko microstructure. Contact with sharp objects may damage the pad surface and impair function. The Gecko Gripper performance is maximized when the pads are clean and dry. The pads can collect dust, so it is best to use the Gecko Gripper in a clean environment and/or establish a routine cleaning schedule.

Part	Description of Maintenance	Frequency
Pad Cleaning	Routine cleaning: Cleaning Station	Dependent on operating conditions. Guidelines are: See Cleaning Station User Guide
Pad Wear	Replacement due to wear	150000 – 200000 for HIGH preload operation 200000 – 250000 for LOW preload operation

Replacing the Gripper Pads

Gecko Gripper pads are designed to last for 200,000-300,000 cycles under typical operating conditions. If the pads do not seem to be gripping properly, even with routine cleaning (see table in the previous page), we recommend fully replacing the gripper pads.

To replace the gripper pads, use the provided pad removal tool.

Step 1: Move gripper pads to the maximum extruded setting such that the pads are maximally exposed/visible.

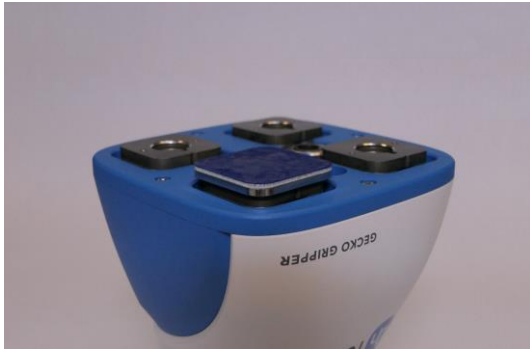

Step 2: Insert the edge of the pad removal tool between the shiny silver plate of the pads and the dull backing plate. Leverage the pad removal tool against the gripper housing to pry off the used pad. Repeat for all pads.



Step 3: To install new replacement pads, align the notch of the pad with the tab in the mounting hole. Push the pad into the gripper until there are no gaps between the shiny silver pad plate and backing plate.

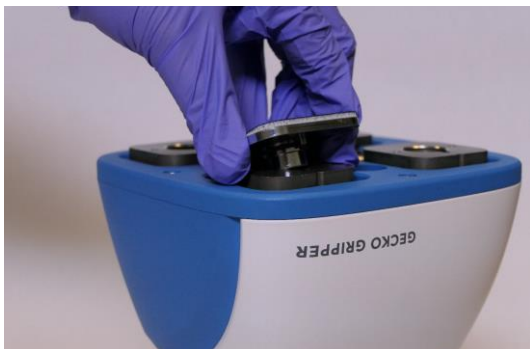

RG2/6**WARNING:**

An overall inspection of the PLd CAT3 Safety Buttons must be performed regularly and at least once every 6 months.

RG2-FT**WARNING:**

Please clean the proximity sensor surface regularly with low pressure compressed air (<5 bar) from a 5 cm distance. For stronger contamination use isopropyl alcohol with a soft cotton swab to keep it clean.

VG10 / VGC10

The VG grippers are equipped with one filter for each suction cup socket, and one filter for the exhaust. How often the filters need to be changed depends on the nature of the work piece and the working environment. The VG grippers automatically de-dust the filters every time a grip is released. However, particles can eventually get stuck and build up inside the filter, lowering the VG grippers performance.

A filter service kit is available, which include both new filters and tools needed.

Filter service kit for VG10, PN 100064

Filter service kit for VGC10, PN 103757

Neither use nor power on the VG grippers without filters. Dust, hair and larger particles can get stuck in pump membranes and valve seats, causing permanent damage to the VG grippers.

**DANGER:**

Identify how often the filters need service and schedule maintenance with a fixed period short enough to ensure a firm grip at all times.

An overall inspection of the VG grippers must be performed regularly and at least once every 6 months.

Never power the VG grippers without filters or with filters mounted incorrectly. Failure to comply with this precaution can cause irreversible failure of pump or valves.

9 Warranties

9.1 Patents

Products of OnRobot A/S are protected by several patents; some still in global publication process (Patents pending). All manufacturers of copies and similar products violating any patent claims will be prosecuted.

9.2 Product Warranty

Without prejudice to any claim the user (customer) may have in relation to the dealer or retailer, the customer shall be granted a manufacturer's warranty under the conditions set out below:

In the case of new devices and their components exhibiting defects resulting from manufacturing and/or material faults within 12 months of entry into service (maximum of 15 months from shipment), OnRobot A/S shall provide the necessary spare parts, while the customer (user) shall provide working hours to replace the spare parts, either replace the part with another part reflecting the current state of the art, or repair the said part. This warranty shall be invalid if the device defect is attributable to improper treatment and/or failure to comply with information contained in the user guides. This warranty shall not apply to or extend to services performed by the authorized dealer or the customer themselves (e.g. installation, configuration, software downloads). The purchase receipt, together with the date of purchase, shall be required as evidence for invoking the warranty. Claims under the warranty must be submitted within two months of the warranty default becoming evident. Ownership of devices or components replaced by and returned to OnRobot A/S shall vest in OnRobot A/S. Any other claims resulting out of or in connection with the device shall be excluded from this warranty. Nothing in this warranty shall attempt to limit or exclude a customer's statutory rights nor the manufacturer's liability for death or personal injury resulting from its negligence. The duration of the warranty shall not be extended by services rendered under the terms of the warranty. Insofar as no warranty default exists, OnRobot A/S reserves the right to charge the customer for replacement or repair. The above provisions do not imply a change in the burden of proof to the detriment of the customer. In case of a device exhibiting defects, OnRobot A/S shall not be liable for any indirect, incidental, special or consequential damages, including but not limited to, lost profits, loss of use, loss of production or damage to other production equipment.

In case of a device exhibiting defects, OnRobot A/S shall not cover any consequential damage or loss, such as loss of production or damage to other production equipment.

9.3 Disclaimer

OnRobot A/S continues to improve reliability and performance of its products, and therefore reserves the right to upgrade the product without prior warning. OnRobot A/S ensures that the content of this manual is precise and correct but takes no responsibility for any errors or missing information.

10 Certifications

ZERTIFIKAT CERTIFICATE

Hiermit wird bescheinigt, dass die Firma / *This certifies that the company*

OnRobot A/S
 Teglværksvej 47H
 5220 Odense SØ
 Denmark

berechtigt ist, das unten genannte Produkt mit dem abgebildeten Zeichen zu kennzeichnen
is authorized to provide the product mentioned below with the mark as illustrated

Fertigungsstätte: <i>Manufacturing plant:</i>	OnRobot A/S Teglværksvej 47H 5220 Odense SØ Denmark
Beschreibung des Produktes: <i>(Details s. Anlage 1)</i> <i>Description of product:</i> <i>(Details see Annex 1)</i>	Safety Gripper for collaborative robots RG2 v2 and RG6 v2
Geprüft nach: <i>Tested in accordance with:</i>	EN ISO 13849-1:2015 Cat. 3, PL ,d'

Registrier-Nr. / <i>Registered No.</i> 44 780 18106002 Prüfbericht Nr. / <i>Test Report No.</i> 3523 2689 Aktenzeichen / <i>File reference</i> 8000489144	Gültigkeit / <i>Validity</i> von / <i>from</i> 2019-06-04 bis / <i>until</i> 2024-06-03
-----------------------------------------------------------------------------------------------------------------------------------------------------------------	-----------------------------------------------------------------------------------------------

Zertifizierungsstelle der
TÜV NORD CERT GmbH

Essen, 2019-06-04

TÜV NORD CERT GmbH Langemarckstraße 20 45141 Essen www.tuev-nord-cert.de technology@tuev-nord.de

Bitte beachten Sie auch die umseitigen Hinweise
Please also pay attention to the information stated overleaf



CERTIFICATE OF REGISTRATION

This is to certify that the management system of:

OnRobot A/S

Main Site: Teglværksvej 47 H, 5220 Odense SØ, Denmark
Chamber of Commerce: 36492449

Additional Site: OnRobot A/S, Cikorievej 44, 5220 Odense SØ, Denmark

has been registered by Intertek as conforming to the requirements of

ISO 9001:2015

The management system is applicable to:

Development and sales of End-of-Arms tools for industrial customers worldwide.

Certificate Number:

0096721

Initial Certification Date:

26 November 2019

Date of Certification Decision:

26 November 2019

Issuing Date:

26 November 2019

Valid Until:

25 November 2022



Intertek



Accred. no. 1639
Certification of
Management
Systems
ISO/IEC 17021-1

Carl-Johan von Plomgren
MD, Business Assurance Nordics

Intertek Certification AB
P.O. Box 1103, SE-164 22 Kista, Sweden



In the issuance of this certificate, Intertek assumes no liability to any party other than to the Client, and then only in accordance with the agreed upon Certification Agreement. This certificate's validity is subject to the organization maintaining their system in accordance with Intertek's requirements for systems certification. Validity may be confirmed via email at certificate.validation@intertek.com or by scanning the code to the right with a smartphone. The certificate remains the property of Intertek, to whom it must be returned upon request.





Report Number: **B91115V1**
 EN 61000-6-2 and EN 55011 Test Report
Gecko Gripper
 Model: *GEN2*

GENERAL REPORT SUMMARY

This electromagnetic emission and immunity test report is generated by Compatible Electronics Inc., which is an independent testing and consulting firm. The test report is based on testing performed by Compatible Electronics personnel according to the measurement procedures described in the test specifications given below and in the “Test Procedures” section of this report.

The measurement data and conclusions appearing herein relate only to the sample tested and this report may not be reproduced without the written permission of Compatible Electronics, unless done so in full.

This report must not be used to claim product certification, approval or endorsement by NVLAP, NIST or any agency of the federal government.

Device Tested: Gecko Gripper
 Model: GEN2
 S/N: RAPUNZEL

Product Description: The equipment under test is a robotic attachment that makes it possible to lift flat, smooth, and level surfaces.

Modifications: The EUT was not modified in order to comply with specifications.

Customer: OnRobot Los Angeles
 8928 Ellis Avenue
 Los Angeles, California 90034

Test Dates: October 4; November 12, 13, 14 and 15, 2019

Test Specifications covered by Accreditation:
 Emissions and Immunity Requirements European Standards:
 EN 61000-6-2 (2005), EN 55011 (2016) + A1 (2017); IEC 61000-3-2 (2014); and IEC 61000-3-3 (2013)



EN 61000-6-2 (2005) is a product family immunity standard that references the following specifications:

- EN 61000-4-2 (2009)
- EN 61000-4-3 (2006) + A1 (2008) + A2: 2010
- EN 61000-4-4 (2004) + A1 (2010)
- EN 61000-4-5 (2006)
- EN 61000-4-6 (2009)
- EN 61000-4-8 (2009)
- EN 61000-4-11 (2004)

Brea Division
 114 Olinda Drive
 Brea, CA 92823
 (714) 579-0500

Newbury Park Division
 1050 Lawrence Drive
 Newbury Park, CA 91320
 (805) 480-4044

Lake Forest Division
 20621 Pascal Way
 Lake Forest, CA 92630
 (949) 587-0400



Attestation of Conformity no. 119-29901-A1

FORCE Technology has performed compliance testing on electrical products since 1967. FORCE Technology is an accredited test house according to EN17025 and participates in international standardization with organizations such as CEN/CENELEC, IEC/CISPR and ETSI. This attestation of conformity with the below mentioned standards and/or normative documents is based on accredited tests and/or technical assessments carried out at FORCE Technology.

<p>Attestation holder</p> <p>OnRobot A/S Teglværksvej 47H 5220 Odense SØ Denmark.</p>													
<p>Product identification</p> <p>Compute box with Power Supply Unit (PSU) VER36U240-JA. Mountings: HEX-E QC V3 (101904), QC – R v2 (102037), Dual QC v2 (101788). Tools: VG10 v2 (101661), RG2 v2 (102012), RG2-FT v2 (102075), RG6 v2 (102021).</p>													
<p>Manufacturer</p> <p>On Robot A/S</p>													
<p>Technical documentation</p> <p>Assessment no. 119-29901-A1</p>													
<p>Standards list no. 1:</p> <table border="0"> <tr> <td>IEC 61000-3-2:2014</td> <td>EMC Directive 2014/30/EU, Article 6</td> </tr> <tr> <td>IEC 61000-3-3:2013</td> <td>EN 61000-3-2:2014</td> </tr> <tr> <td>IEC 61000-6-2:2016</td> <td>EN 61000-3-3:2013</td> </tr> <tr> <td>IEC 61000-6-4:2018</td> <td>EN 61000-6-2:2005</td> </tr> <tr> <td></td> <td>EN 61000-6-2:2019</td> </tr> <tr> <td></td> <td>EN 61000-6-4:2007 + A1:2011</td> </tr> </table> <p>Standard list no. 2: (applicable specifically to RG2 v2 (102012) and RG6 v2 (102021))</p> <p>IEC 61326-3-1:2017, Industry locations, SIL 2</p> <p>The product identified above has been assessed and complies with the specified standards/normative documents. The attestation does not include any market surveillance. It is the responsibility of the manufacturer that mass-produced apparatus have the same properties and quality. This attestation does not contain any statements pertaining to the requirements pursuant to other standards, directives or laws other than the above mentioned.</p>		IEC 61000-3-2:2014	EMC Directive 2014/30/EU, Article 6	IEC 61000-3-3:2013	EN 61000-3-2:2014	IEC 61000-6-2:2016	EN 61000-3-3:2013	IEC 61000-6-4:2018	EN 61000-6-2:2005		EN 61000-6-2:2019		EN 61000-6-4:2007 + A1:2011
IEC 61000-3-2:2014	EMC Directive 2014/30/EU, Article 6												
IEC 61000-3-3:2013	EN 61000-3-2:2014												
IEC 61000-6-2:2016	EN 61000-3-3:2013												
IEC 61000-6-4:2018	EN 61000-6-2:2005												
	EN 61000-6-2:2019												
	EN 61000-6-4:2007 + A1:2011												
<p>Signature</p> <p>Knud A. Baltsen</p>	<p>Digitally signed by Knud A. Baltsen Date: 2019.11.15 19:38:04 +01'00'</p>												
<p>Signed by: Knud A. Baltsen, Senior Specialist, Product Compliance</p>													



Attestation of Conformity no. 118-33022-A1

FORCE Technology has performed compliance testing on electrical products since 1967. FORCE Technology is an accredited test house according to EN17025 and participates in international standardization with organizations such as CEN/CENELEC, IEC/CISPR and ETSI. This attestation of conformity with the below mentioned standards and/or normative documents is based on accredited tests and/or technical assessments carried out at FORCE Technology.

<p>Attestation holder</p> <p>OnRobot A/S Teglværksvej 47H 5220 Odense SØ Denmark</p>			
<p>Product identification</p> <p>Gripper RG2 2.0</p>			
<p>Manufacturer</p> <p>OnRobot A/S</p>			
<p>Technical documentation</p> <p>FORCE Technology Test Report 117-29737, dated 01 September 2017 FORCE Technology Assessment Sheet 1668, dated 17 October 2017 FORCE Technology Test Report 118-33022-2 Rev. 1, dated 06 February 2019 FORCE Technology Assessment 118-33022-A1, dated 21 February 2019</p>			
<p>Standards/Normative documents</p> <table border="0" style="width: 100%;"> <tr> <td style="width: 50%; vertical-align: top;"> <p>IEC 61000-6-2:2005 IEC 61000-6-4:2006 + A1:2010 IEC 61326-3-1:2017, Industrial locations, SIL 2 FCC Part 15B, Class A</p> </td> <td style="width: 50%; vertical-align: top;"> <p>EMC Directive 2014/30/EU, Article 6 EN 61000-6-2:2005 + AC:2005 EN 61000-6-4:2007 + A1:2011 EN 61326-3-1:2017, Industrial locations, SIL 2</p> </td> </tr> </table> <p>The product identified above has been assessed and complies with the specified standards/normative documents. The attestation does not include any market surveillance. It is the responsibility of the manufacturer that mass-produced apparatus have the same properties and quality. This attestation does not contain any statements pertaining to the requirements pursuant to other standards, directives or laws other than the above mentioned.</p>		<p>IEC 61000-6-2:2005 IEC 61000-6-4:2006 + A1:2010 IEC 61326-3-1:2017, Industrial locations, SIL 2 FCC Part 15B, Class A</p>	<p>EMC Directive 2014/30/EU, Article 6 EN 61000-6-2:2005 + AC:2005 EN 61000-6-4:2007 + A1:2011 EN 61326-3-1:2017, Industrial locations, SIL 2</p>
<p>IEC 61000-6-2:2005 IEC 61000-6-4:2006 + A1:2010 IEC 61326-3-1:2017, Industrial locations, SIL 2 FCC Part 15B, Class A</p>	<p>EMC Directive 2014/30/EU, Article 6 EN 61000-6-2:2005 + AC:2005 EN 61000-6-4:2007 + A1:2011 EN 61326-3-1:2017, Industrial locations, SIL 2</p>		
<p>Signature</p> <div style="text-align: center;"> <p>Knud A. Baltzen 2019-02-21</p> <p>Digitally signed by Knud A. Baltzen kab@force.dk Senior Specialist</p> </div> <p>Signed by: Knud A. Baltzen, Senior Specialist, Product Compliance</p>			



Attestation of Conformity no. 118-33022-A2

FORCE Technology has performed compliance testing on electrical products since 1967. FORCE Technology is an accredited test house according to EN17025 and participates in international standardization with organizations such as CEN/CENELEC, IEC/CISPR and ETSI. This attestation of conformity with the below mentioned standards and/or normative documents is based on accredited tests and/or technical assessments carried out at FORCE Technology.

Attestation holder	
OnRobot A/S Teglværksvej 47H 5220 Odense SØ Denmark	
Product identification	
Gripper RG6 2.0	
Manufacturer	
OnRobot A/S	
Technical documentation	
FORCE Technology Test Report 117-29737, dated 01 September 2017 FORCE Technology Assessment Sheet 1668, dated 17 October 2017 FORCE Technology Test Report 118-33022-2 Rev. 1, dated 06 February 2019 FORCE Technology Assessment 118-33022-A1, dated 21 February 2019	
Standards/Normative documents	
IEC 61000-6-2:2005 IEC 61000-6-4:2006 + A1:2010 IEC 61326-3-1:2017, Industrial locations, SIL 2 FCC Part 15B, Class A	EMC Directive 2014/30/EU, Article 6 EN 61000-6-2:2005 + AC:2005 EN 61000-6-4:2007 + A1:2011 EN 61326-3-1:2017, Industrial locations, SIL 2
<p>The product identified above has been assessed and complies with the specified standards/normative documents. The attestation does not include any market surveillance. It is the responsibility of the manufacturer that mass-produced apparatus have the same properties and quality. This attestation does not contain any statements pertaining to the requirements pursuant to other standards, directives or laws other than the above mentioned.</p>	
Signature	<p>Knud A. Baltzen 2019-02-21</p> <p>Digitally signed by Knud A. Baltzen kab@force.dk Senior Specialist</p>
Signed by: Knud A. Baltzen, Senior Specialist, Product Compliance	

10.1 Declaration of Incorporation

Gecko

CE/EU Declaration of Incorporation (Original)

According to European Machinery Directive 2006/42/EC annex II 1.B.

The manufacturer:

OnRobot A/S
 Teglværskvej 47H
 DK-5220, Odense SØ
 DENMARK

declares that the product:

Type:	Industrial Robot Gripper
Model:	Gecko Gripper
Generation:	V2
Serial:	1000000000-1009999999

may not be put into service before the machinery in which it will be incorporated is declared in conformity with the provisions of Directive 2006/42/EC, including amendments, and with the regulations transposing it into national law.

The product is prepared for compliance with all essential requirements of Directive 2006/42/EC under the correct incorporation conditions, see instructions and guidance in this manual. Compliance with all essential requirements of Directive 2006/42/EC relies on the specific robot installation and the final risk assessment.

Technical documentation is compiled according to Directive 2006/42/EC annex VII part B and available in electronic form to national authorities upon legitimate request. Undersigned is based on the manufacturer address and authorized to compile this documentation.

Additionally, the product declares in conformity with the following directives, according to which the product is CE marked:

- 2014/30/EU — Electromagnetic Compatibility Directive (EMC)
- 2011/65/EU — Restriction of the use of certain hazardous substances (RoHS)

Relevant essential health and safety requirements of the following EU directives are also applied:

- 2014/35/EU — Low Voltage Directive (LVD)
- 2012/19/EU — Waste of Electrical and Electronic Equipment (WEEE)

A list of applied harmonized standards, including associated specifications, is provided in this manual.

Budapest, December 16th, 2019

Group Management



Vilmos Beskid
 CTO

HEX-E

CE/EU Declaration of Incorporation (Original)

According to European Machinery Directive 2006/42/EC annex II 1.B.

The manufacturer:

OnRobot A/S
 Teglværskvej 47H
 DK-5220, Odense SØ
 DENMARK

declares that the product:

Type: Industrial Force/Torque Sensor
 Model: HEX-E QC
 Generation: V3
 Serial: 1000000000-1009999999

may not be put into service before the machinery in which it will be incorporated is declared in conformity with the provisions of Directive 2006/42/EC, including amendments, and with the regulations transposing it into national law.

The product is prepared for compliance with all essential requirements of Directive 2006/42/EC under the correct incorporation conditions, see instructions and guidance in this manual. Compliance with all essential requirements of Directive 2006/42/EC relies on the specific robot installation and the final risk assessment.

Technical documentation is compiled according to Directive 2006/42/EC annex VII part B and available in electronic form to national authorities upon legitimate request. Undersigned is based on the manufacturer address and authorized to compile this documentation.

Additionally, the product declares in conformity with the following directives, according to which the product is CE marked:

2014/30/EU — Electromagnetic Compatibility Directive (EMC)
 2011/65/EU — Restriction of the use of certain hazardous substances (RoHS)

Relevant essential health and safety requirements of the following EU directives are also applied:

2014/35/EU — Low Voltage Directive (LVD)
 2012/19/EU — Waste of Electrical and Electronic Equipment (WEEE)

A list of applied harmonized standards, including associated specifications, is provided in this manual.

Budapest, December 16th, 2019

Group Management



Vilmos Beskid
 CTO

HEX-H**CE/EU Declaration of Incorporation (Original)**

According to European Machinery Directive 2006/42/EC annex II 1.B.

The manufacturer:

OnRobot A/S
Teglværskvej 47H
DK-5220, Odense SØ
DENMARK

declares that the product:

Type: Industrial Force/Torque Sensor
Model: HEX-H QC
Generation: V3
Serial: 1000000000-1009999999

may not be put into service before the machinery in which it will be incorporated is declared in conformity with the provisions of Directive 2006/42/EC, including amendments, and with the regulations transposing it into national law.

The product is prepared for compliance with all essential requirements of Directive 2006/42/EC under the correct incorporation conditions, see instructions and guidance in this manual. Compliance with all essential requirements of Directive 2006/42/EC relies on the specific robot installation and the final risk assessment.

Technical documentation is compiled according to Directive 2006/42/EC annex VII part B and available in electronic form to national authorities upon legitimate request. Undersigned is based on the manufacturer address and authorized to compile this documentation.

Additionally, the product declares in conformity with the following directives, according to which the product is CE marked:

2014/30/EU — Electromagnetic Compatibility Directive (EMC)
2011/65/EU — Restriction of the use of certain hazardous substances (RoHS)

Relevant essential health and safety requirements of the following EU directives are also applied:

2014/35/EU — Low Voltage Directive (LVD)
2012/19/EU — Waste of Electrical and Electronic Equipment (WEEE)

A list of applied harmonized standards, including associated specifications, is provided in this manual.

Budapest, December 16th, 2019

Group Management



Vilmos Beskid
CTO

RG2-FT
CE/EU Declaration of Incorporation (Original)

According to European Machinery Directive 2006/42/EC annex II 1.B.

The manufacturer:

OnRobot A/S
 Teglværskvej 47H
 DK-5220, Odense SØ
 DENMARK

declares that the product:

Type:	Industrial Robot Gripper
Model:	RG2-FT
Generation:	V2
Serial:	1000000000-1009999999

may not be put into service before the machinery in which it will be incorporated is declared in conformity with the provisions of Directive 2006/42/EC, including amendments, and with the regulations transposing it into national law.

The product is prepared for compliance with all essential requirements of Directive 2006/42/EC under the correct incorporation conditions, see instructions and guidance in this manual. Compliance with all essential requirements of Directive 2006/42/EC relies on the specific robot installation and the final risk assessment.

Technical documentation is compiled according to Directive 2006/42/EC annex VII part B and available in electronic form to national authorities upon legitimate request. Undersigned is based on the manufacturer address and authorized to compile this documentation.

Additionally, the product declares in conformity with the following directives, according to which the product is CE marked:

2014/30/EU — Electromagnetic Compatibility Directive (EMC)
 2011/65/EU — Restriction of the use of certain hazardous substances (RoHS)

Relevant essential health and safety requirements of the following EU directives are also applied:

2014/35/EU — Low Voltage Directive (LVD)
 2012/19/EU — Waste of Electrical and Electronic Equipment (WEEE)

A list of applied harmonized standards, including associated specifications, is provided in this manual.

Budapest, December 16th, 2019

Group Management



Vilmos Beskid
 CTO

RG2

CE/EU Declaration of Incorporation (Original)

According to European Machinery Directive 2006/42/EC annex II 1.B.

The manufacturer:

OnRobot A/S
Teglværskvej 47H
DK-5220, Odense SØ
DENMARK

declares that the product:

Type: Industrial Robot Gripper
Model: RG2
Generation: V2
Serial: 1000000000-1009999999

may not be put into service before the machinery in which it will be incorporated is declared in conformity with the provisions of Directive 2006/42/EC, including amendments, and with the regulations transposing it into national law.

The product is prepared for compliance with all essential requirements of Directive 2006/42/EC under the correct incorporation conditions, see instructions and guidance in this manual. Compliance with all essential requirements of Directive 2006/42/EC relies on the specific robot installation and the final risk assessment.

Technical documentation is compiled according to Directive 2006/42/EC annex VII part B and available in electronic form to national authorities upon legitimate request. Undersigned is based on the manufacturer address and authorized to compile this documentation.

Additionally, the product declares in conformity with the following directives, according to which the product is CE marked:

2014/30/EU — Electromagnetic Compatibility Directive (EMC)
2011/65/EU — Restriction of the use of certain hazardous substances (RoHS)

Relevant essential health and safety requirements of the following EU directives are also applied:

2014/35/EU — Low Voltage Directive (LVD)
2012/19/EU — Waste of Electrical and Electronic Equipment (WEEE)

A list of applied harmonized standards, including associated specifications, is provided in this manual.

Budapest, December 16th, 2019

Group Management



Vilmos Beskid
CTO

RG6
CE/EU Declaration of Incorporation (Original)

According to European Machinery Directive 2006/42/EC annex II 1.B.

The manufacturer:

OnRobot A/S
 Teglværskvej 47H
 DK-5220, Odense SØ
 DENMARK

declares that the product:

Type:	Industrial Robot Gripper
Model:	RG6
Generation:	V2
Serial:	1000000000-1009999999

may not be put into service before the machinery in which it will be incorporated is declared in conformity with the provisions of Directive 2006/42/EC, including amendments, and with the regulations transposing it into national law.

The product is prepared for compliance with all essential requirements of Directive 2006/42/EC under the correct incorporation conditions, see instructions and guidance in this manual. Compliance with all essential requirements of Directive 2006/42/EC relies on the specific robot installation and the final risk assessment.

Technical documentation is compiled according to Directive 2006/42/EC annex VII part B and available in electronic form to national authorities upon legitimate request. Undersigned is based on the manufacturer address and authorized to compile this documentation.

Additionally, the product declares in conformity with the following directives, according to which the product is CE marked:

2014/30/EU — Electromagnetic Compatibility Directive (EMC)
 2011/65/EU — Restriction of the use of certain hazardous substances (RoHS)

Relevant essential health and safety requirements of the following EU directives are also applied:

2014/35/EU — Low Voltage Directive (LVD)
 2012/19/EU — Waste of Electrical and Electronic Equipment (WEEE)

A list of applied harmonized standards, including associated specifications, is provided in this manual.

Budapest, December 16th, 2019

Group Management



Vilmos Beskid
 CTO

VG10
CE/EU Declaration of Incorporation (Original)

According to European Machinery Directive 2006/42/EC annex II 1.B.

The manufacturer:

OnRobot A/S
 Teglværskvej 47H
 DK-5220, Odense SØ
 DENMARK

declares that the product:

Type:	Industrial Robot Gripper
Model:	VG10
Generation:	V2
Serial:	1000000000-1009999999

may not be put into service before the machinery in which it will be incorporated is declared in conformity with the provisions of Directive 2006/42/EC, including amendments, and with the regulations transposing it into national law.

The product is prepared for compliance with all essential requirements of Directive 2006/42/EC under the correct incorporation conditions, see instructions and guidance in this manual. Compliance with all essential requirements of Directive 2006/42/EC relies on the specific robot installation and the final risk assessment.

Technical documentation is compiled according to Directive 2006/42/EC annex VII part B and available in electronic form to national authorities upon legitimate request. Undersigned is based on the manufacturer address and authorized to compile this documentation.

Additionally, the product declares in conformity with the following directives, according to which the product is CE marked:

2014/30/EU — Electromagnetic Compatibility Directive (EMC)
 2011/65/EU — Restriction of the use of certain hazardous substances (RoHS)

Relevant essential health and safety requirements of the following EU directives are also applied:

2014/35/EU — Low Voltage Directive (LVD)
 2012/19/EU — Waste of Electrical and Electronic Equipment (WEEE)

A list of applied harmonized standards, including associated specifications, is provided in this manual.

Budapest, December 16th, 2019

Group Management



Vilmos Beskid
 CTO

VGC10

CE/EU Declaration of Incorporation (Original)

According to European Machinery Directive 2006/42/EC annex II 1.B.

The manufacturer:

OnRobot A/S
 Teglværskvej 47H
 DK-5220, Odense SØ
 DENMARK

declares that the product:

Type:	Industrial Robot Gripper
Model:	VGC10
Generation:	V1
Serial:	1000000000-1009999999

may not be put into service before the machinery in which it will be incorporated is declared in conformity with the provisions of Directive 2006/42/EC, including amendments, and with the regulations transposing it into national law.

The product is prepared for compliance with all essential requirements of Directive 2006/42/EC under the correct incorporation conditions, see instructions and guidance in this manual. Compliance with all essential requirements of Directive 2006/42/EC relies on the specific robot installation and the final risk assessment.

Technical documentation is compiled according to Directive 2006/42/EC annex VII part B and available in electronic form to national authorities upon legitimate request. Undersigned is based on the manufacturer address and authorized to compile this documentation.

Additionally, the product declares in conformity with the following directives, according to which the product is CE marked:

2014/30/EU — Electromagnetic Compatibility Directive (EMC)
 2011/65/EU — Restriction of the use of certain hazardous substances (RoHS)

Relevant essential health and safety requirements of the following EU directives are also applied:

2014/35/EU — Low Voltage Directive (LVD)
 2012/19/EU — Waste of Electrical and Electronic Equipment (WEEE)

A list of applied harmonized standards, including associated specifications, is provided in this manual.

Budapest, December 16th, 2019

Group Management



Vilmos Beskid
 CTO