

DATASHEET

2FGP20

v1.9

1. Datasheet

1.1. 2FGP20

Finger Grip Properties		Minimum	Typical	Maximum	Unit
Payload		-	-	20	[kg]
		-	-	44.1	[lb]
Total stroke		-	260		[mm]
		-	10.24		[inch]
Grip width range ⁽¹⁾		170	-	430	[mm]
		6.69	-	16.93	[inch]
Gripping repeatability		-	+/- 0.5	-	[mm]
		-	+/- 0.0197	-	[inch]
Gripping force ⁽²⁾		80	-	400	[N]
Gripping force tolerance		-	-	+/- 30	[N]
Gripping speed		16	-	180	[mm/s]
Gripping time (including brake activation) ⁽³⁾		-	600	-	[ms]
Noise level ⁽⁴⁾	Finger gripper	-	-	58 63	[dB(A)] _{Leq} [dB(A)] _{Max}
	Vacuum gripper	-	-	72 74	[dB(A)] _{Leq} [dB(A)] _{Max}
Hold workpiece in case of power loss?	Yes				
Motor	Integrated, electric BLDC				

⁽¹⁾ When pads are mounted, the minimum value is 158 mm and the maximum value is 418 mm.

⁽²⁾ See [Force vs Current Graph](#)

⁽³⁾ At 6 mm stroke and 150 N. The typical value is 900 ms at 20 mm and 200 N.

⁽⁴⁾ For more information, see the [Noise level](#) section.

Vacuum grip properties	Minimum	Typical	Maximum	Unit
Vacuum	5	-	60	[%Vacuum]
	- 0.05	-	- 0.607	[Bar]
	1.5	-	17.95	[inHg]
Air flow	0		12	[L/min]
Payload (with delivered attachments)		-	2.5	[kg]
		-	5.51	[lb]
Vacuum cups	1		4	[pcs]
Gripping time (measured with vacuum target 40 %)		0.25		[s]

Vacuum grip properties	Minimum	Typical	Maximum	Unit
Release time		0.4		[s]
Vacuum pump	Integrated, electric BLDC			
Dust filters	Integrated 50 µm, field replaceable			

General properties	Minimum	Typical	Maximum	Unit
Storage temperature	0	-	60	[°C]
	32	-	140	[°F]
IP Classification	54			
Dimensions [L x W x D]	400 x 121.6 x 188 15.75 x 4.79 x 7.4			[mm] [inch]

Gripper combination	Base unit	Standard fingers including four pads	Vacuum equipment	KLT Finger set	Total weight	Unit
Base unit with Standard fingers including all pads	3.7	1.37	-	-	5.07	[kg]
	8.16	3.02			11.18	[lb]
Base unit with Standard fingers including all pads and all vacuum equipment	3.7	1.37	0.27	-	5.34	[kg]
	8.16	3.02	0.60		11.77	[lb]
Base unit with KLT Finger set	3.7	-	-	0.43	4.13	[kg]
	8.16			0.95	9.11	[lb]
Base unit with KLT Finger set and all vacuum equipment	3.7	-	0.27	0.43	4.4	[kg]
	8.16		0.60	0.95	9.7	[lb]
Base unit with custom fingers	3.7	-	-	-	User defined	[kg]
	8.16					[lb]

Operating Conditions	Minimum	Typical	Maximum	Unit
Power supply	20	24	25	[V]
Current consumption	-	-	2000	[mA]
Operating temperature (gripper and vacuum cups)	5	-	50	[°C]
	41	-	122	[°F]
Relative humidity (non-condensing)	0	-	95	[%]

Warranty: 3 years or 3.000.000 cycles, whichever comes first, as per the official warranty terms set out in the Partner Agreement. One operating cycle is defined as one complete grip and release sequence, equivalent to 6,000,000 open or close movements.

Force vs Current Graph

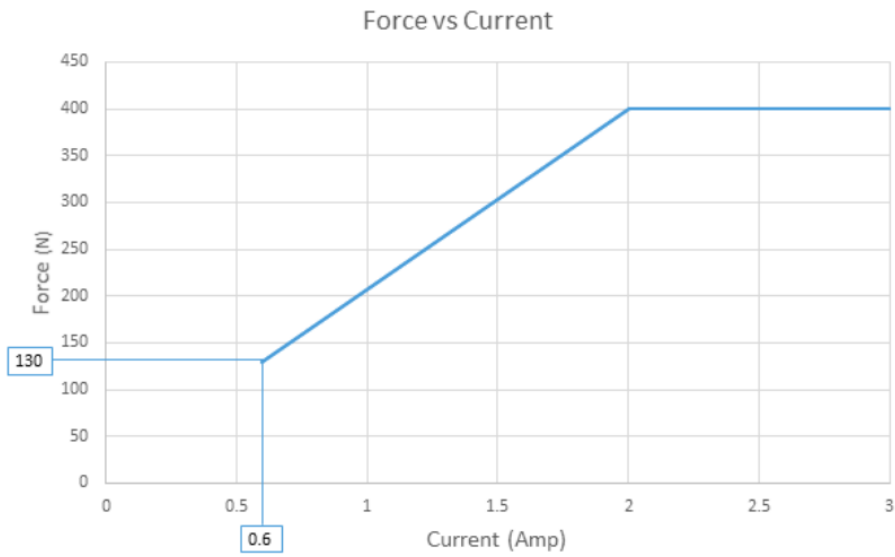

2FGP20 Reinforcement Bracket



NOTE:

The reinforcement bracket must be used with robots rated for payloads of 20 kg and above.



The Reinforcement Bracket enhances the gripper's robustness. It also increases the torque capacity by an additional 40 Nm, complementing the total allowable torque with the QC torque. The bracket weight is 0.45 kg (0.99 lb).

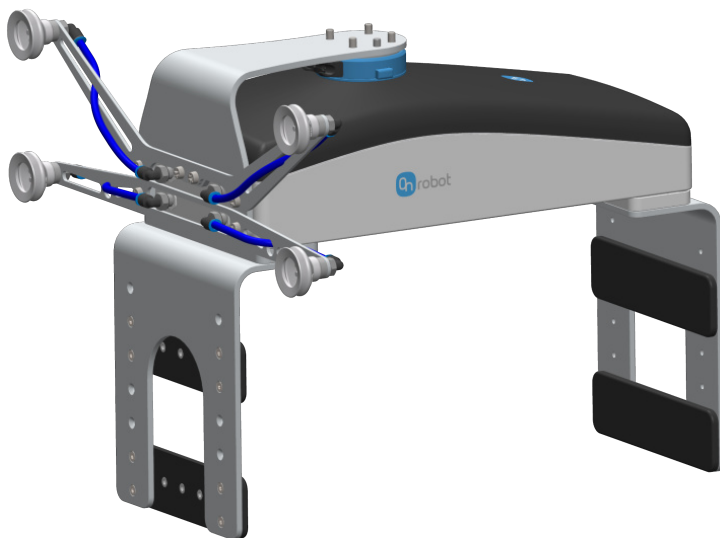

Noise Level

The noise level of the 2FGP20 depends on whether the finger or vacuum gripping part is used. Vacuum gripping noise depends on the set vacuum level and whether an object is picked up or not. Higher speed and stroke increase the noise. The noise level also depends on the surroundings and other equipment.

To measure the 2FGP20's noise level, a test has been carried out by an external company.

The test setup was the following:

- The test took place in a normal indoor production area.
- The finger gripping test ran 4 cycles full stroke, 100 % speed and with no pause in between the cycles.
- The vacuum gripping test was made with fully activated pump and with no pause.
- The noise measurement equipment was located in 1 m distance away from the 2FGP20.

The test concludes that the average measured noise level was below 58 dB(A)_{Leq} for the finger gripper and 72 dB(A)_{Leq} for the vacuum. The maximum noise level was measured below 63 dB(A)_{Max} for the finger gripper and 74 dB(A)_{Max} for the vacuum, which is below the maximum allowed noise level of (80 dB(A)). The 2FGP20 will not run continuously in an application which means that the average noise level will decrease significantly.

Force Sensor

The gripper has a force sensor in the moving finger as shown in the figure below.

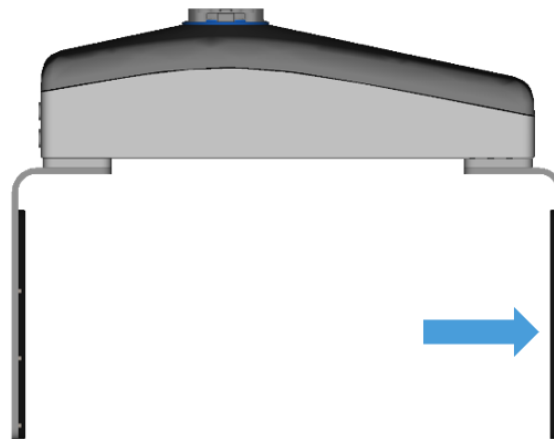

Consider the presence of the force sensor when the workpiece is aligned by using the fingers of the gripper or when the workpiece is picked sideways since the gravity can affect the force measurement.

If the workpiece is picked sideways, make sure to orient the gripper with the moving finger on top, as shown in the image below. Also ensure that the bottom finger makes contact with the workpiece before the top finger.

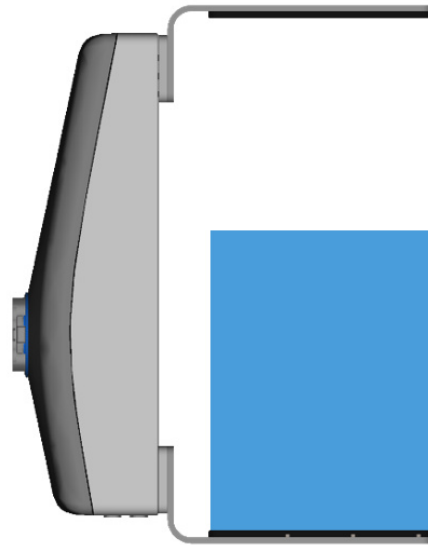

Finger pads

Four finger pads are provided with the gripper and can be mounted in different configurations to achieve the best grip for your workpiece.

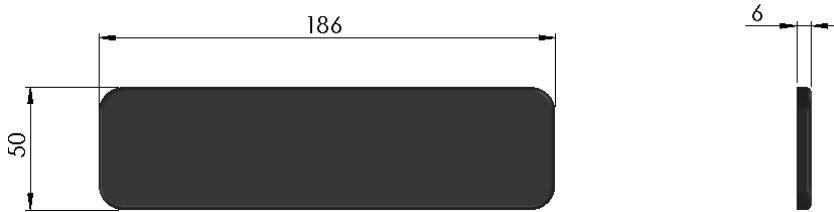

Some examples of how the pads can be mounted are shown below.

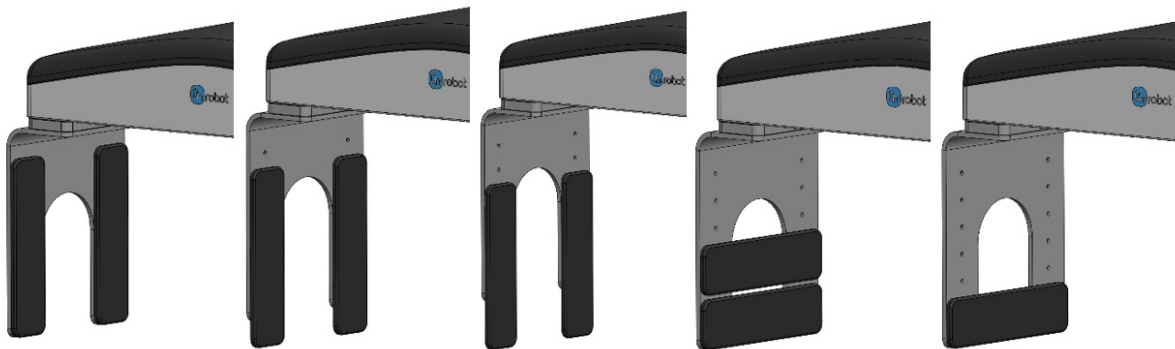

The pads are made of aluminum with a cover of silicone. The maximum force (equally distributed in the blue area of the images below) that can be applied to the finger pads is shown in the table below.

Illustration	Pad position	Maximum force (N)
	0	400
	1	300
	2	200
	3	100

Illustration	Pad position	Maximum force (N)
	4	400
	5	400

Finger set for KLT boxes

The Finger set for KLT boxes enhances the grip stability for KLT containers and other open box types with groove. The fingertips can be adjusted to the open slots on the large variants of boxes.



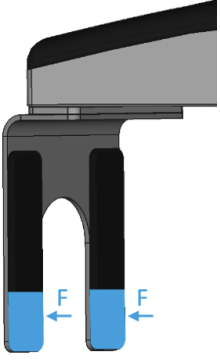
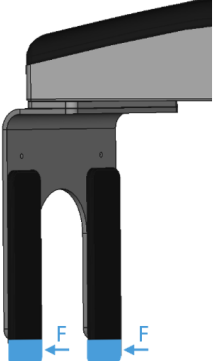
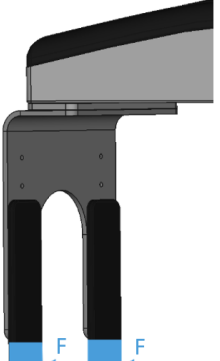
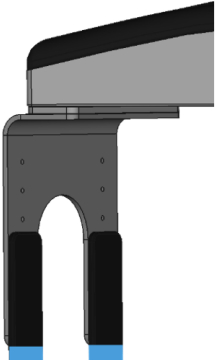
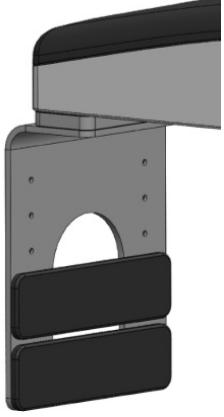
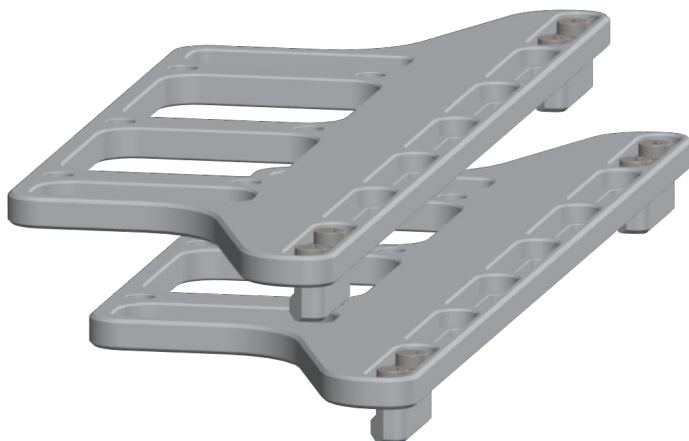
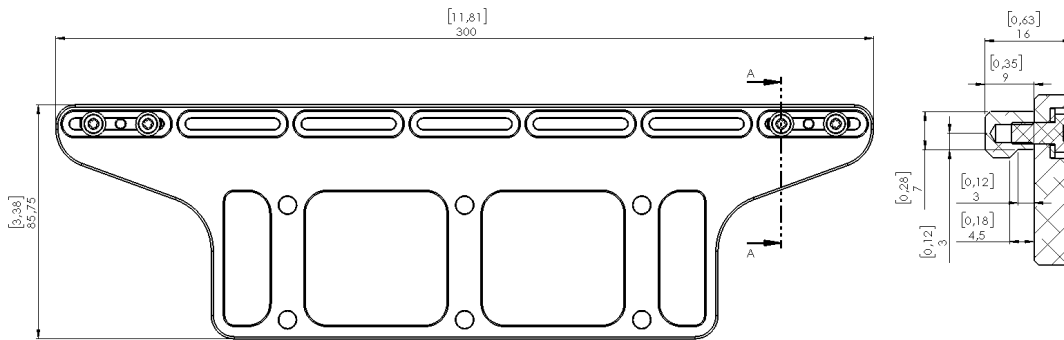

These fingers are accessories and need to be purchased separately. To purchase these fingers, please contact the vendor from where the gripper has been purchased.

- 2FGP20 - Finger set for KLT boxes PN 113294

See examples with 400 x 300 mm and 600 x 400 KLT boxes:

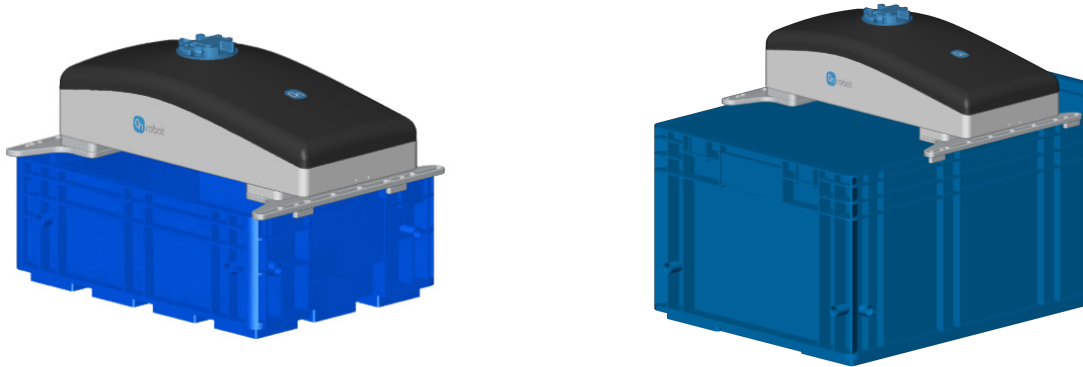

It is recommended to use KLT boxes using the VDA standard 4500. Because of the variance of stiffness in the different KLT boxes, the application needs to be tested in regards to payload and robot speed/acceleration.

Custom fingers

The standard fingers provided with the gripper have a height of 220 mm. For workpieces taller than 220 mm, it is recommended to customize the fingers.



WARNING:

Observe ISO/TR 20218-1 and ISO/TS 15066 so custom fingers are not sharp or create pinching hazards in the gripping areas.

An example is shown in the picture below where the pressure is recommended to be applied at the bottom of the workpiece. To achieve this, custom longer fingers are used, and the fingerpads are attached horizontally. This is the best way to get a firm grip.

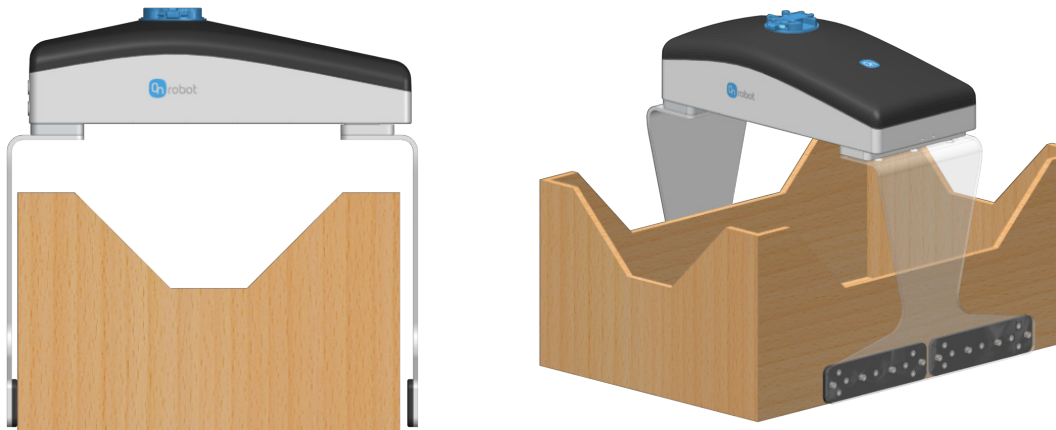

By increasing the finger height, the allowed torque might be reduced as shown in the [Moments in the finger base](#) section.

Another example is shown in the image below for picking wrapped foil bottles. For this workpiece type, it is recommended to mount the pads horizontally to have as many contact points as possible. By doing so, the applied force can be increased and a firmer grip is achieved. Place the pads as close to the bottom of the workpiece as possible, so the workpiece structure is stronger and can resist more force.

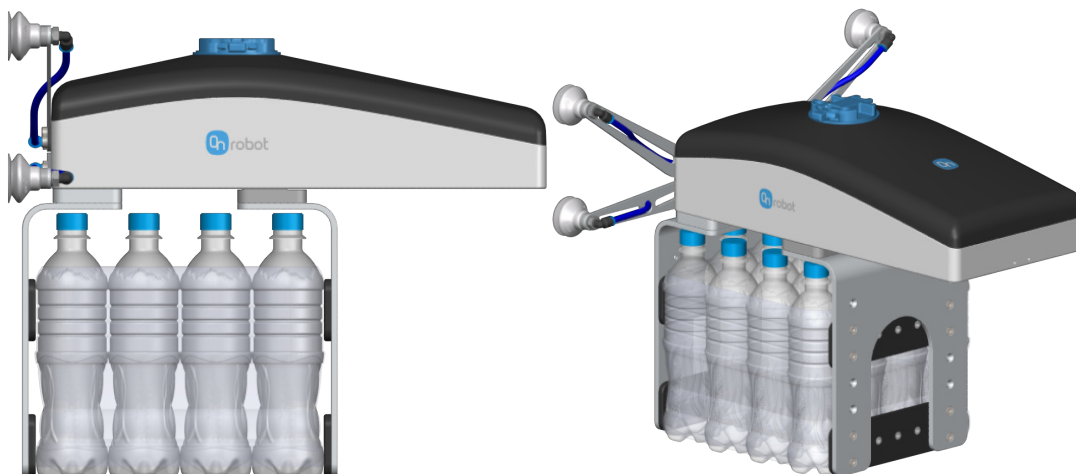

If custom fingers are required, they can be made to fit the gripper according to the dimensions (mm) [inch] shown below. Use M6x10mm screws to attach the fingers.

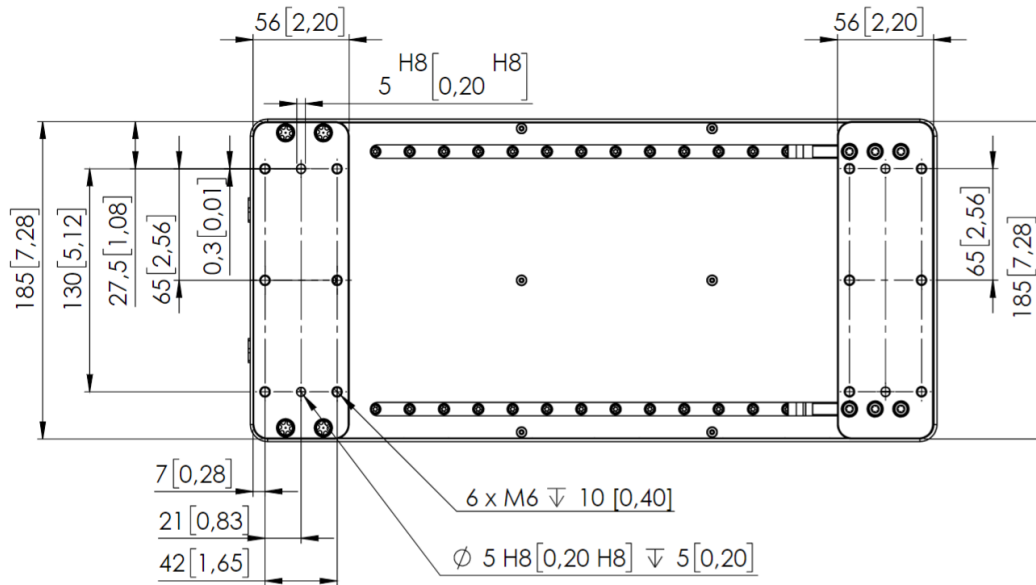

Moments in the finger base

A maximum moment 80 Nm is allowed on each direction of the finger base.

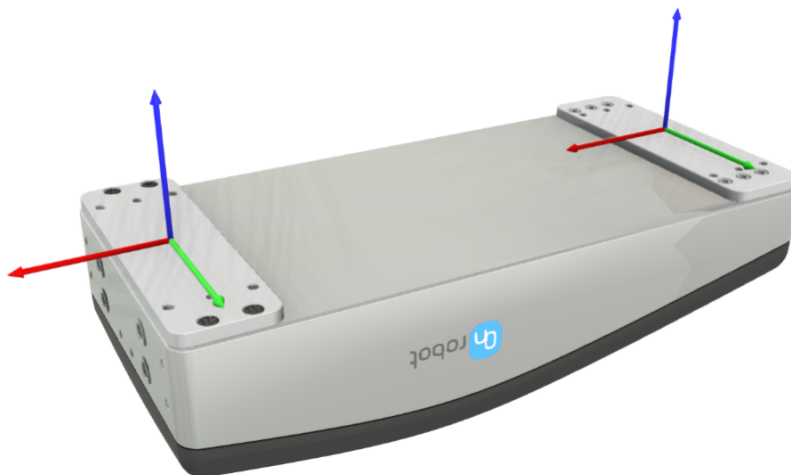

Vacuum cups

The vacuum solution has been designed to handle interlayer sheets and similar items. The two most common configurations with the delivered bracket and vacuum cups are shown below.

Square Shape	Row Shape
Better for cardboard interlayer sheets or multiple layer paper	Better for paper or similar interlayer sheets

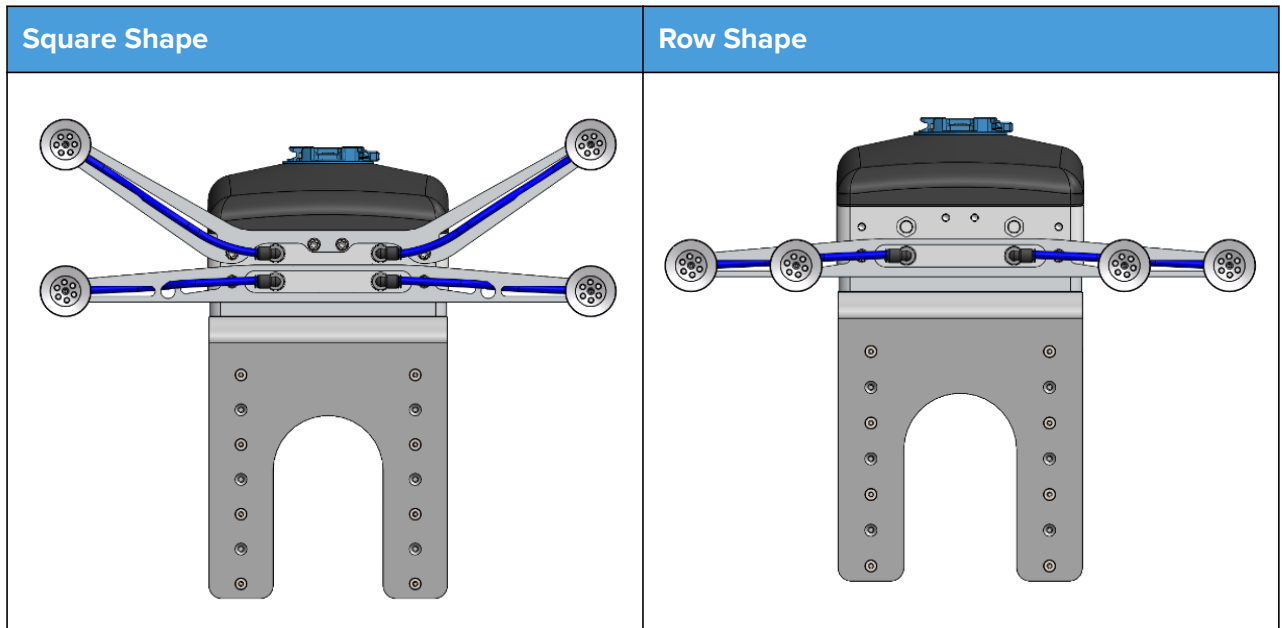

The provided tube length is adequate for the Square Shape. For using the Row Shape, please cut two of the tubes to 83 mm length.



NOTE:

It is important to always use the four air sources together.

Custom Vacuum Bracket

If a custom bracket is required, it can be made to fit the gripper according to the dimensions (mm) [inch] shown below. Use M6x6mm screws to attach the fingers.

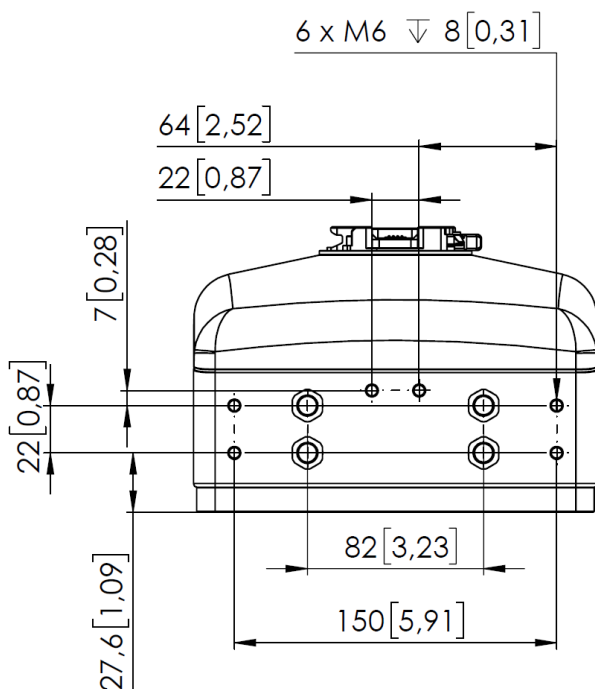

1.2. 2FGP20 box content

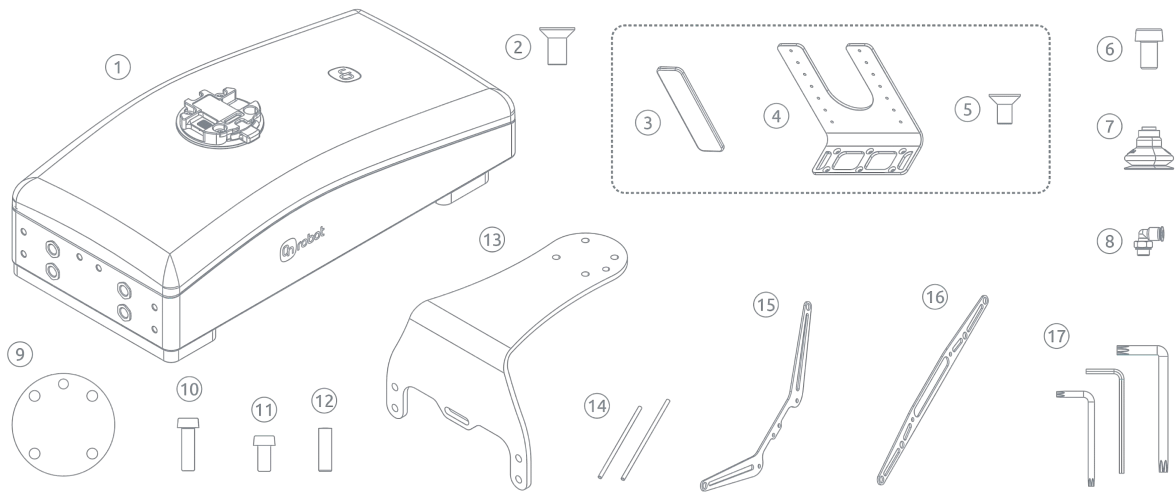

- | | | | | |
|-------------------------------|---|-----------------------------|--|--------------------------------|
| ① 2FGP20 Base Unit | ② 12 x M6x12mm Screw | ③ 4 x Finger Pad Premounted | ④ 2 x 2FGP20 Finger | ⑤ 16 x M4x8mm screw Premounted |
| ⑥ 6 x M6x10mm screw | ⑦ 4 x Suction Cup Ø40 | ⑧ 8 x Angled Fitting | ⑨ Distance plate | ⑩ 4 x M6x20mm screw |
| ⑪ 6 x M6x12mm screw | ⑫ Ø6h8x20mm Pin | ⑬ Reinforcement Bracket | ⑭ 2 x Vacuum Tube L = 160
2 x Vacuum Tube L = 180 | ⑮ Suction cup bracket V-Shape |
| ⑯ Suction cup bracket I-Shape | ⑰ Torx T30 key Hex key 3 mm
 Torx T20 key | | | |

1.3. 2FGP20

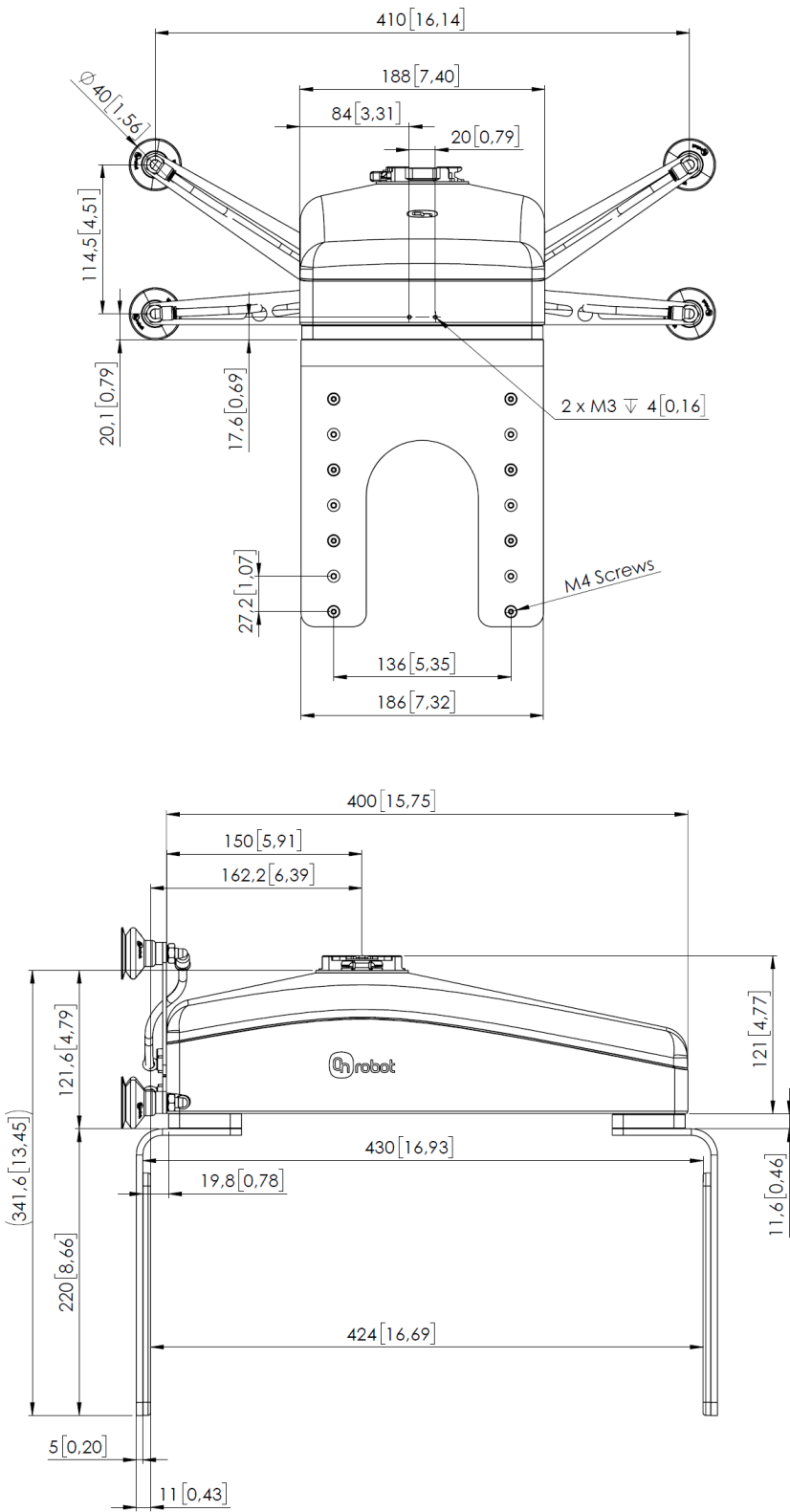

2FGP20 with Reinforcement Bracket

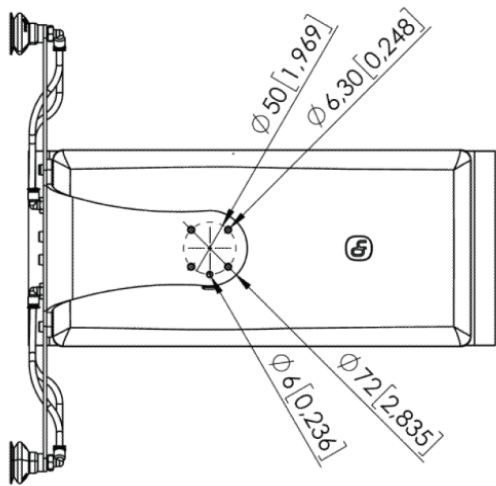
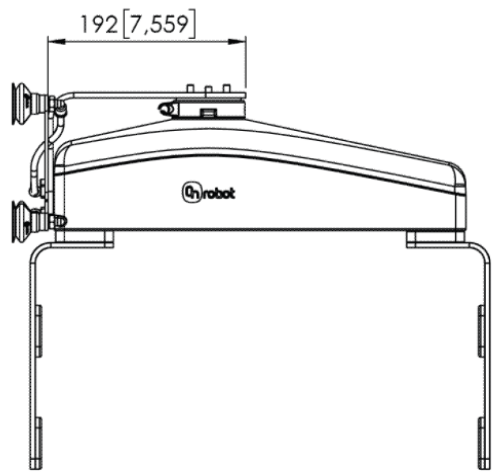
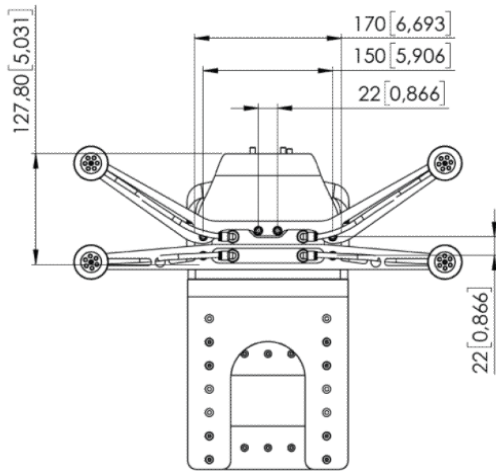

All dimensions are in mm and [inches].