





DATASHEET

3FG25

v1.3

1. Datasheet

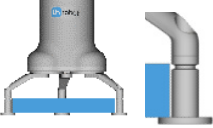
1.1. 3FG25

General Properties		Minimum	Typical	Maximum	Unit
Payload Force Fit 	Grip	- -	- -	15 33.06	[kg] [lb]
	Flexible grip	- -	- -	10 22	[kg] [lb]
Payload Form Fit 		- -	- -	25 55.1	[kg] [lb]
Grip Diameter*	External 	18 0.70	- -	155 6.10	[mm] [inch]
	Internal 	41 1.61	- -	184 7.24	[mm] [inch]
Finger position resolution		- -	0.1 0.004	- -	[mm] [inch]
Diameter repetition accuracy		- -	0.1 0.004	0.2 0.007	[mm] [inch]
Motor torque on finger platform (z)**		-	-	7.4	[Nm]
Gripping force	Grip	50	-	450	[N]
	Flexible grip	50	-	300	[N]
Gripping force (adjustable)		1	-	100	[%]
Gripping speed (diameter change)		-	-	90	[mm/s]
Gripping time (including brake activation) * * *		-	500	-	[ms]
Minimum necessary diameter change		3	-	-	[mm]
Hold workpiece if power loss?		Yes			
Storage temperature		0	-	60	[°C]
		32	-	140	[°F]
Motor		Integrated, electric BLDC			
IP Classification		IP67			
Dimensions [L, W, Ø]		156 x 168 x 187 6.16 x 6.62 x 7.38			[mm] [inch]
Weight		1.6			
		3.52			
					[kg] [lb]

* With the scope of delivery.

** See where torque is applied in [Maximum Allowed Torque](#).

*** 10 mm diameter distance. Also see section [Gripping methods](#).

Operating Conditions	Minimum	Typical	Maximum	Unit
Power supply	20	24	25	[V]
Current consumption	50	-	1500	[mA]
Operating temperature	5	-	50	[°C]
	41	-	122	[°F]
Relative humidity (non-condensing)	0	-	95	[%]

Warranty: 3 years or 3.000.000 cycles, whichever comes first, as per the official warranty terms set out in the Partner Agreement. One operating cycle is defined as one complete grip and release sequence, equivalent to 6,000,000 open or close movements.

Fingers

The supplied fingers can be mounted in 3 different positions to achieve different **Gripping Forces** and different **Gripping Diameters**.

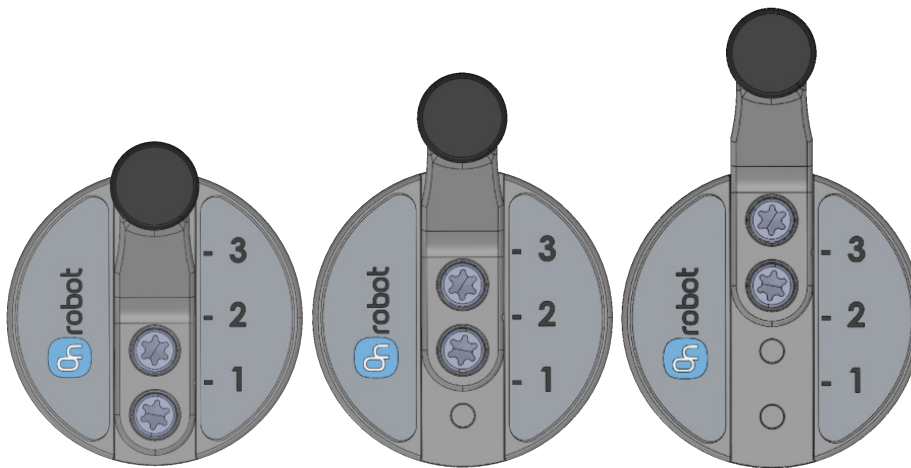

The delivered finger length is 42.6 mm (L in the drawing below). If custom fingers are required, they can be made to fit the gripper according to the dimensions (mm)[inch] shown below. The needed screws are M5x8mm (use 2.5 Nm tightening torque):

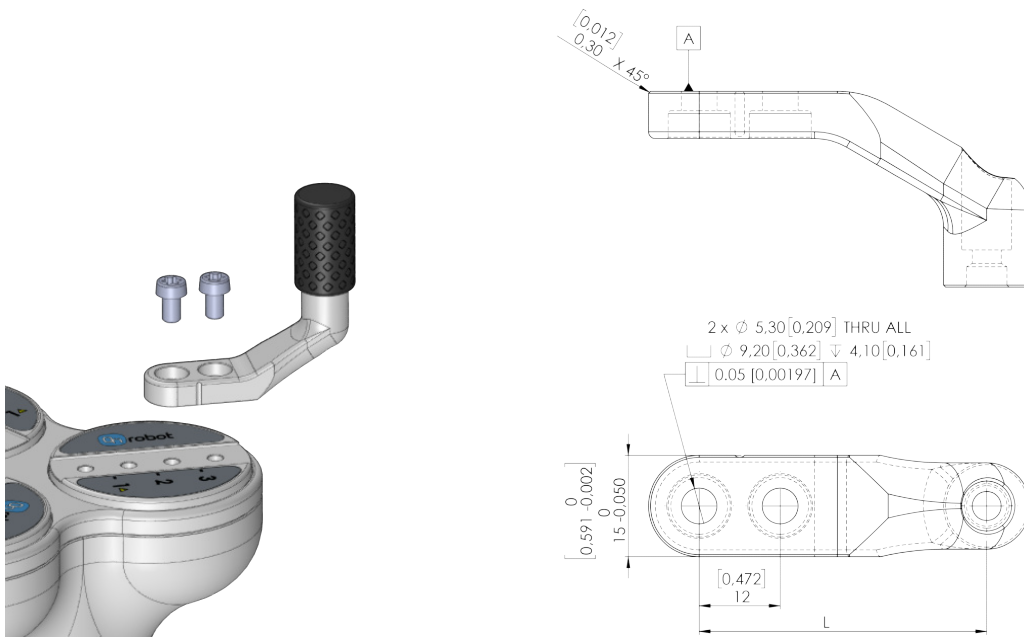

Fingertips

The supplied fingertips are listed below. Different fingertips will allow to achieve different **Gripping Forces** and different **Gripping Diameters**.

- Ø13 mm steel
- Ø13 mm knurled
- Ø16.5 mm NBR

If custom fingertips are required, they can be made to fit the gripper's fingers according to the dimensions (mm)[inch] shown below. The needed screws are M4x8mm (use 2.5 Nm tightening torque):

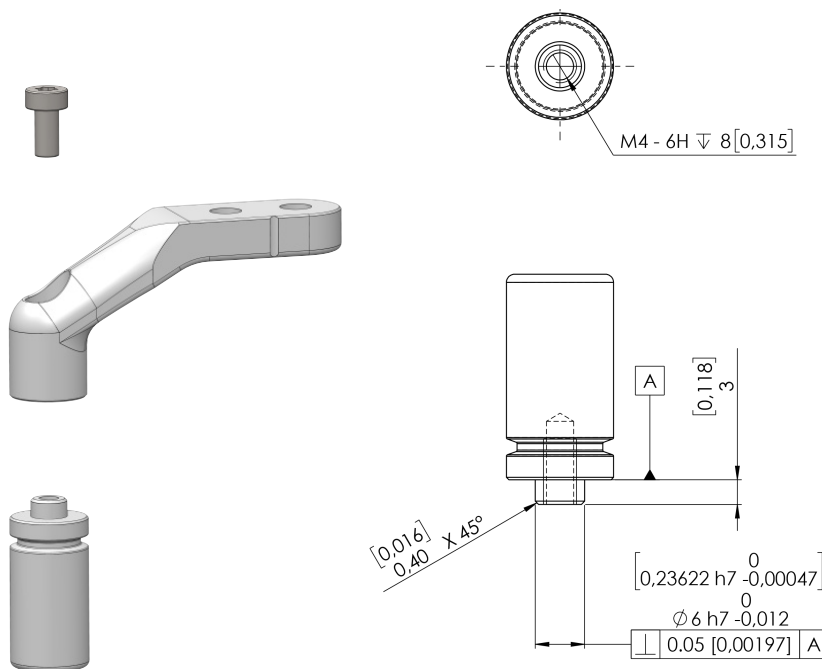

Maximum Allowed Torque

This section is important if custom fingers or fingertips are used.

The maximum allowed torque applied to the gripper finger platforms around X and Y is 40 Nm.

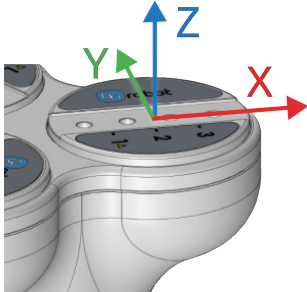

The maximum allowed torque applied to the gripper finger end around X and Y is 8 Nm.

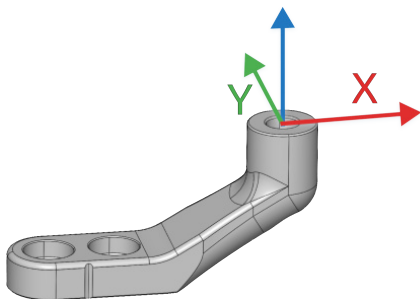

The pictures above show the coordinate system from where the maximum allowed torques are calculated.

X-shape Fingertips

These fingertips improve the gripper's ability to pick and place round workpieces with collar like features. By combining the force fit and the form fit gripping approaches, the fingertips increase the stability and payload of the workpiece to be gripped.

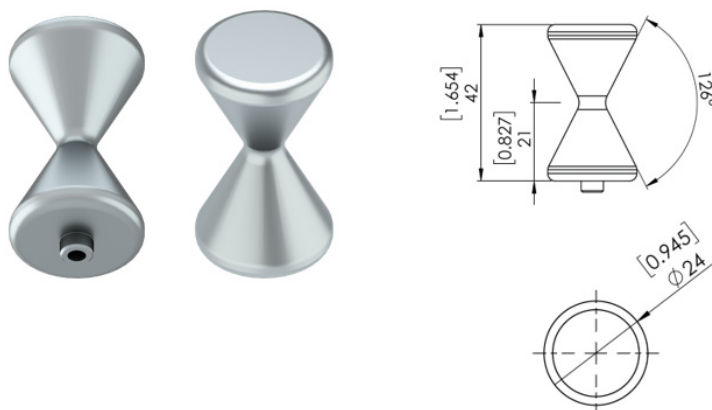

When these fingertips are used, set the fingertip diameter to 16 mm in the robot program. These fingertips are optional accessories and need to be purchased separately. To purchase these fingertips, please contact the distributor.

- 3FG X-Shape Fingertips PN 106963.

Knurled Fingertip Set

Designed with a knurled surface, these fingertips increase friction and payload capacity, making them optimal for gripping and moving raw and oil-coated workpieces in CNC machines.



NOTE:

The knurled fingertip may leave marks on the material.

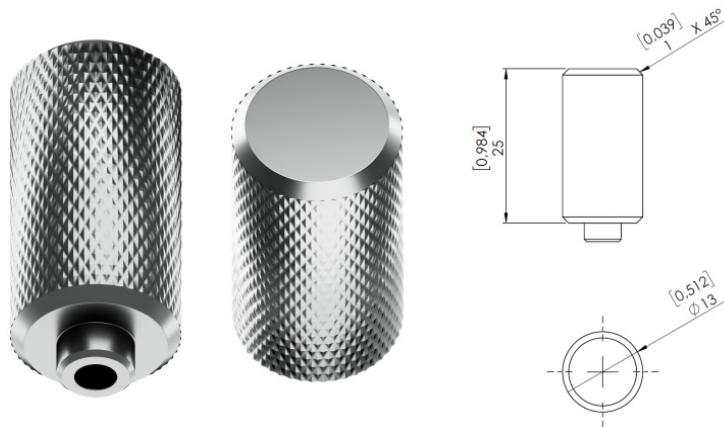

Set the robot program to a 13 mm diameter when using these fingertips.

External/Internal grips

In the document the internal and external grip terms are used. These grips are related to how the workpiece is gripped.

External grip	Internal grip



CAUTION:

Grip heavy or fixed workpieces centered in the gripper. At first contact, no finger may be more than 0.5 mm away from the workpiece. Larger offsets can overload and damage the motor and gear.



Gripping methods

There are two different gripping methods how the 3FG25 can be operated. With each method, both internal and external gripping can be used.

Normal grip	Flexible grip
Use this gripping method if: <ul style="list-style-type: none"> the diameter of the object is known and does not vary more than 300 N gripping force is needed 	Use this gripping method if: <ul style="list-style-type: none"> the diameter of the object is not known or varies significantly up to 300 N gripping force is sufficient

Normal grip

The gripping action has two phases:

Phase 1: For a safety reason, the fingers will start moving with a lower force (<140 N) to avoid damaging anything that could get clamped between the gripper fingers and the workpiece.

Phase 2: When the gripper diameter is very close to the programmed target diameter, the gripper will increase the force to grip with the programmed target force. After the grip, a brake will be activated (tic sound). The activation of the brake, also known as, Force grip detected, can be verified in the provided functions. This brake will hold the workpiece with the applied force, with no power consumption and holding the workpiece in case of power loss. This brake will automatically be deactivated when the gripper performs a release or a new grip command. While programming the gripper, the brake can be deactivated by using the features in the GUI.

Flexible grip

The fingers will start moving with the set target force. If the gripper gets in contact with the object, it will grip with the programmed target force. After the grip, a brake will be activated (tic sound). The activation of the brake, also known as, Force grip detected, can be verified in the provided functions. This brake will hold the workpiece with the applied force, with no power consumption and holding the workpiece in case of power loss. This brake will automatically be deactivated when the gripper performs a release or a new grip command. While programming the gripper, the brake can be deactivated by using the features in the GUI.

Gripping Force

The total gripping force highly depends on the finger angle θ . For both internal and external grip, the lower the finger angle, the higher the force that will be applied.

The angle range of an external or internal grip is 25-155 degrees.

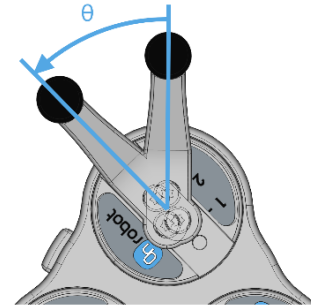

The graph below shows what force can be achieved for a specific diameter depending on the finger position when using the Normal grip function. The graph is plotted using measurements with the standard fingers in all 3 positions, steel fingertips $\varnothing 13$ mm and a metal workpiece.

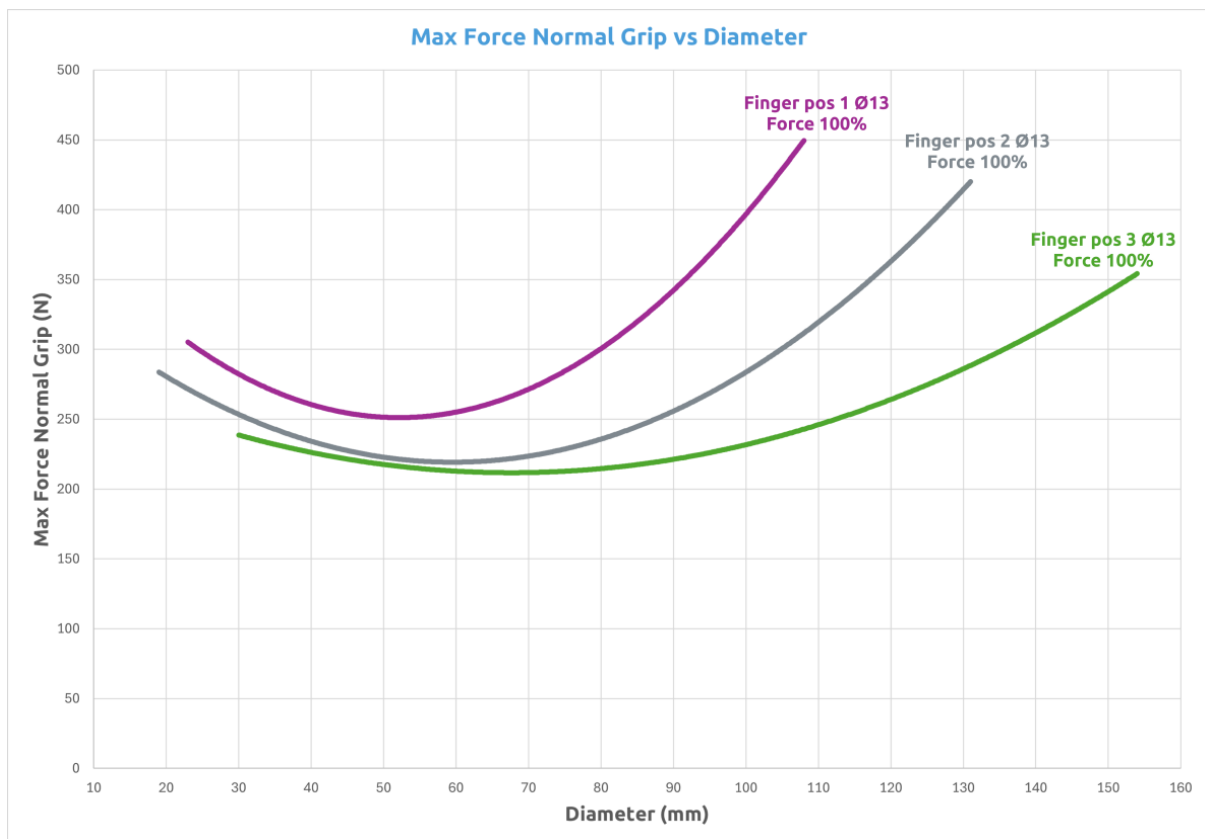

The graph below shows what force can be achieved for a specific diameter depending on the finger position when using the Flexible grip function. 300 N is the max possible value and under no circumstances this value is exceeded. The graph is plotted using measurements with the standard fingers in all 3 positions, steel fingertips $\varnothing 13$ mm and a metal workpiece.

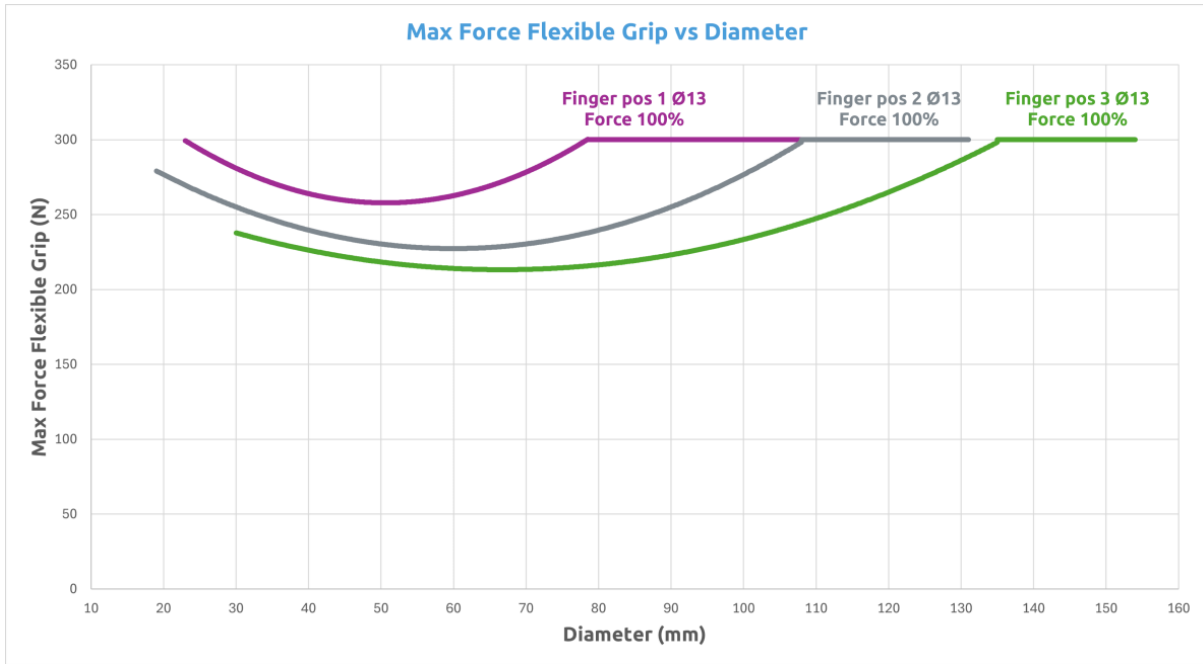

NOTE:

The total force applied depends on the finger angle, the input current (limited in some robots' tool flange connection) and the friction coefficient between the materials of the fingertips and the workpiece.

Gripping Diameter

The different configurations of the delivered finger and fingertips can achieve a wide range of diameters.

Finger Position	Fingertip (mm)	External Gripping Range (mm)	Internal Gripping Range (mm)
1	Ø13	26 - 107	46 - 133
	Ø16.5	22 - 103	49 - 136
2	Ø13	21 - 131	41 - 157
	Ø16.5	18 - 127	45 - 160
3	Ø13	33 - 155	53 - 181
	Ø16.5	29 - 151	56 - 184

Based on 155° and 25° for min and max diameters respectively.

The closer to the maximum diameter range, the lower the angle and, therefore, the higher the force.

Gripping Speed



NOTE:

The achievable gripping speed is affected by the following parameters:

1. Using lower target force (F) than 100% can reduce the gripping speed.
2. The size of the target diameter: the bigger the target diameter (gripping near to fully open position), the lower the achievable gripping speed.

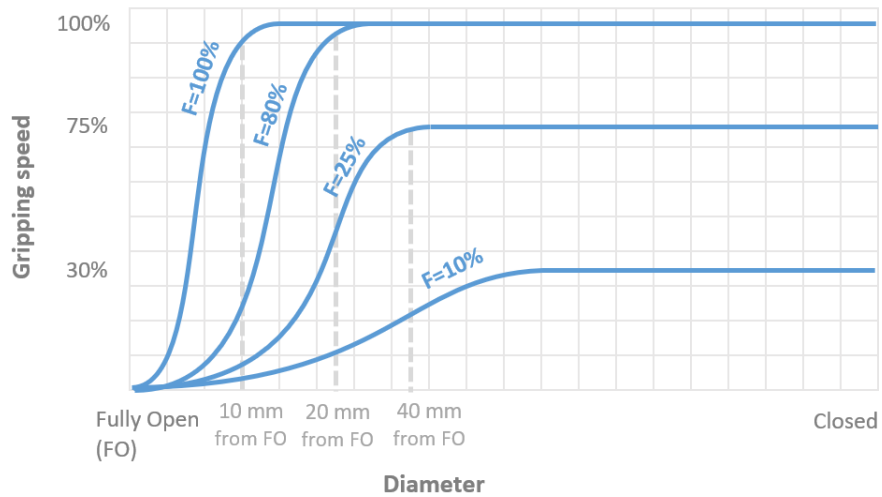

1.2. 3FG25 box content

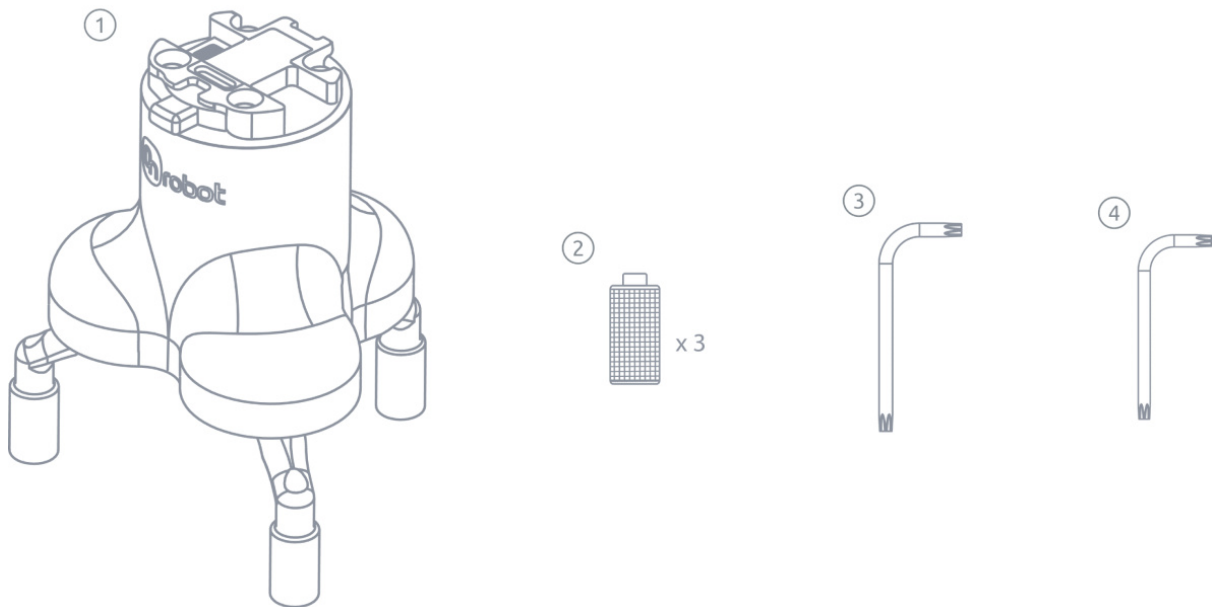

- ① 3FG25 with $\varnothing 13$ steel and $\varnothing 16.5$ NBR fingertips
- ② $\varnothing 13$ knurled steel fingertip x 3
- ③ Torx T25 Key
- ④ Torx T20 Key

1.3. 3FG25

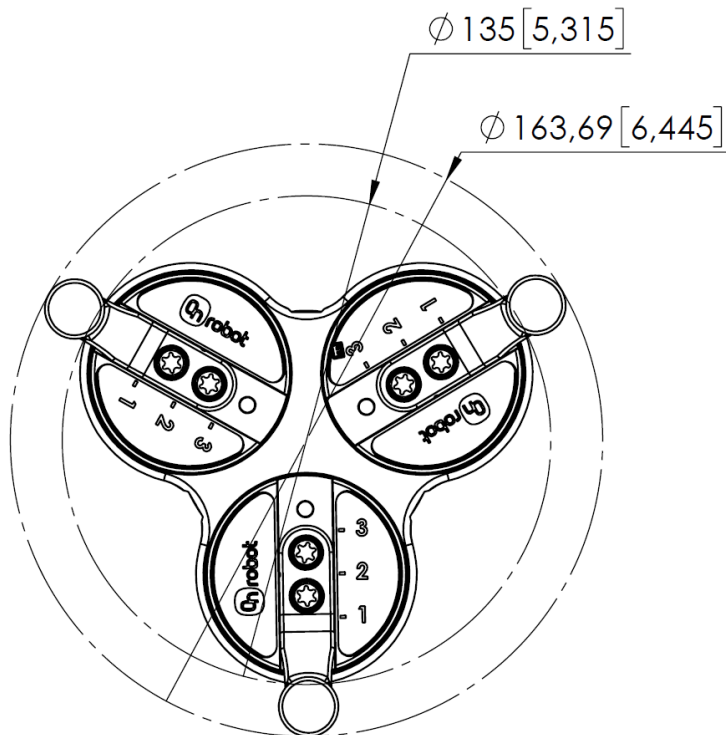
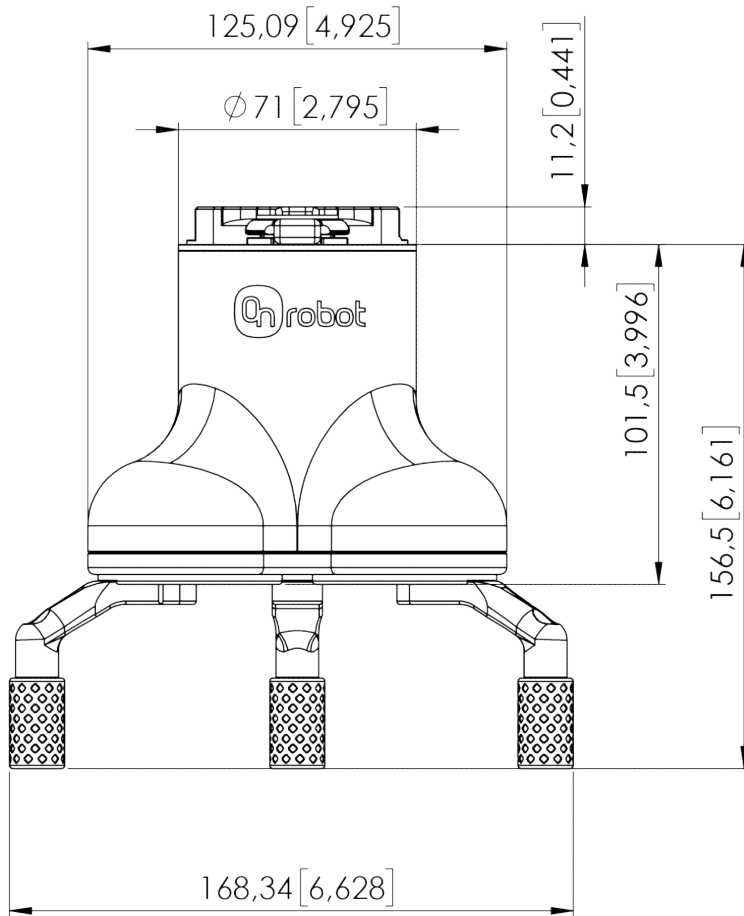

All dimensions are in mm and [inches].